



# AI-driven video analytics systems for industrial safety and operational efficiency

Smart visual intelligence solutions for proactive marine risk management



**Ivan Dukach**

Senior international sales manager  
[ivan.dukach@nvi-solutions.com](mailto:ivan.dukach@nvi-solutions.com)

[ 1 ]



## About NVI Solutions

Technology portfolio, approach and coverage



# About NVI Solutions

## Mission and key figures

The main objective of NVI Solutions is to **enhance production efficiency and safety** through automation of visual information processing

**8**

Years of computer vision expertise

**500+**

Overall staff head count

**6 500+**

Industrial system deployments worldwide

**90%+**

Target recognition precision

**250+**

Scalable use cases for industrial market

**350+**

Service technicians

### Strategic markets

- Oil & gas
- Mining
- Energy
- Chemicals
- Steel
- Machinery
- Light industry
- Construction



**NVI RESEARCH**

# Research

# Development

- Over 40 engineers and scientists
- Over 200 scientific publications
- 6 PhD candidates
- 2 doctors of science

# About NVI Solutions

## Leadership recognition



# About NVI Solutions

## Technology portfolio

### Core technology

#### Industrial video analytics based on artificial intelligence

More than 250 complete industrial scenarios for object recognition and territory/action monitoring using computer vision

*(personnel, transport, PPE, additional equipment, hazardous zones, anomalies, unidentified objects, typical and atypical actions and events)*

Ready-made software products for oil & gas industry and related industrial sectors (mining, steel, chemicals, energy, manufacturing, etc.)

Integration with external systems and equipment (VMS, SCADA, IoT)

### Value added technologies

#### In-vehicle video analytics

Complete monitoring of driver actions and indication of safety violations

#### Personnel and transport positioning solutions

Video analytics enrichment with coordinate data from IoT devices

### Professional services

#### Turnkey implementation

From autonomous drilling and workover sites to production facilities, refineries and plants

#### Equipment selection, supply and configuration

Standard kits and project-specific requirements

### Real-time mode



### Retrospective mode

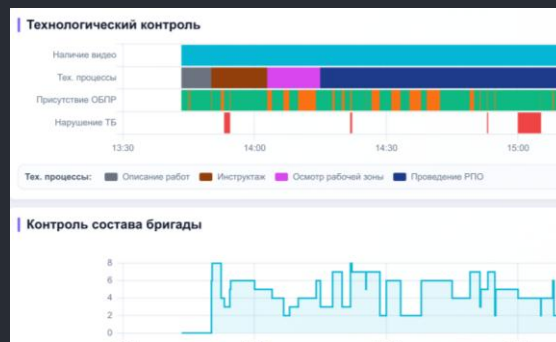

### Automatic image, text and document recognition

Automatic voice recognition from microphones and video, change detection on UAV and satellite imagery, document «reading»

### AR/VR/XR solutions

Digital simulators with virtual environment simulation based on digital twins

### Supervision and technical support 24/7/365

Continuous maintenance of target system operability at deployment and operation sites, neural network uptraining based on real facilities datasets

### IT Consulting and Integration

Consulting team for pre-project surveys and integration with external ecosystem

# About NVI Solutions

Installed base worldwide

**More than 500**

Industrial facilities

Are equipped with edge AI video analytics

**More than 5 000**

Vehicles and transport units

Are equipped with in-cabin video analytics

**More than 10**

International projects

Ongoing in CIS, MENA and SEA regions

**More than 30**

Years of video streaming

Are processed in platform on daily basis

CIS

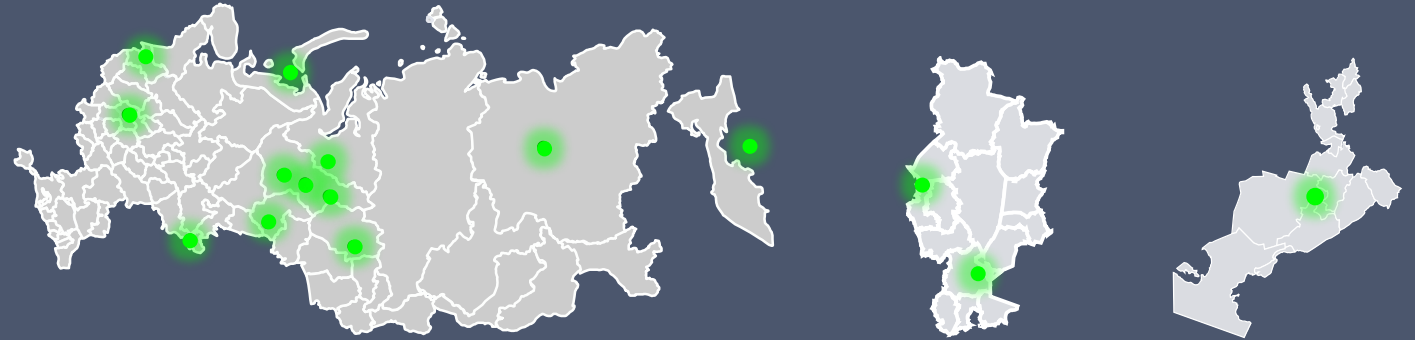

MENA

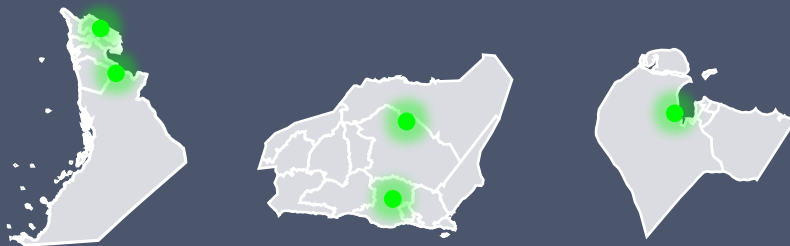

SEA

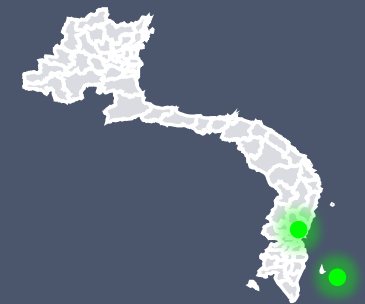

[ 2 ]



## Video analytics in modern safety culture

Key element for achieving target KPIs

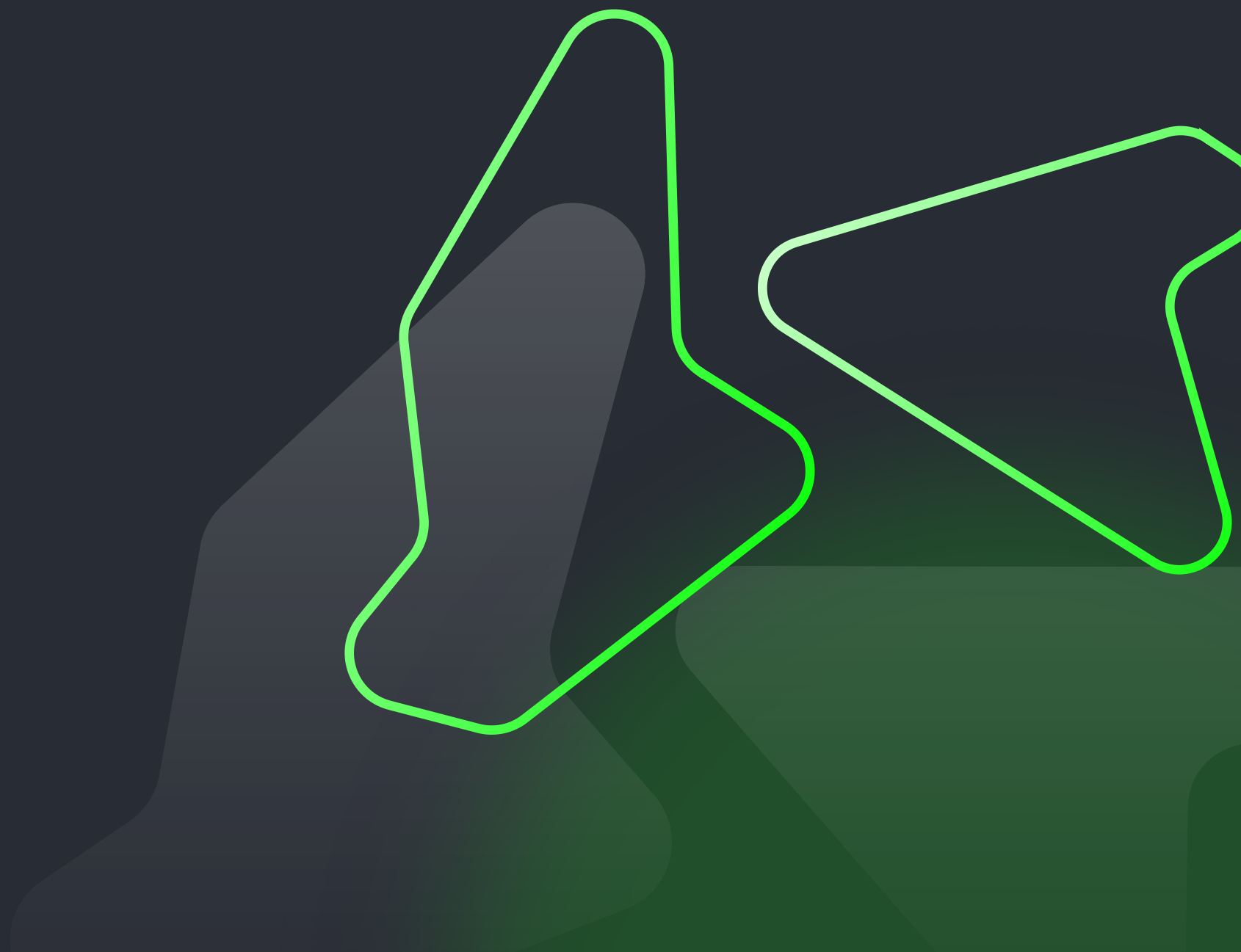

# AI-driven video analytics in modern safety culture

## Impact of human factor on industrial safety

### Proactive metrics

Industrial safety requirements that depend on individual actions are currently met in

**only 77% of cases**



### Reactive metrics

**72% of major incidents**

in 2022–2024 occurred, in part, due to incorrect actions or inaction by personnel

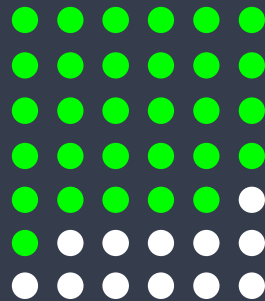

### Key complicating conditions

- **Labor shortage:** Lack of specialists with required qualifications
- **High personnel turnover:** Constant staff changes complicate maintenance of unified safety standards
- **Declining qualification of newcomers:** Decreasing professional level of newly hired employees increases production risks
- **Reactive approach to violations:** Corrective measures are applied to personnel with delays and only on a case-by-case basis
- **Weak incident verification processes:** Companies lack systematic processes for verification and analysis of incidents
- **Resource deficit for monitoring:** Insufficient personnel for comprehensive and continuous monitoring of industrial safety status



One of the most common and difficult-to-solve problems is the **lack of information** needed to form an **objective picture** of industrial safety conditions on facilities

# NVI Solutions AI-driven video analytics platform for marine safety

Key technology for work oversight excellence

Actual coverage:  
**Under 1% of all works**

Work oversight  
by human

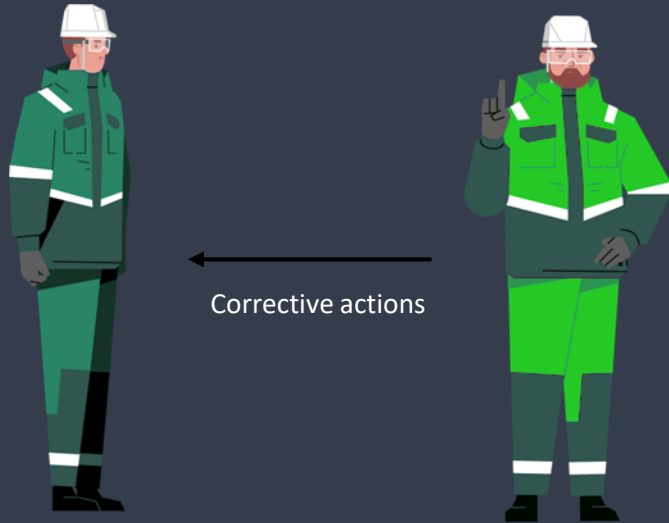

Target coverage:  
**100% of all works 24/7**

Work oversight by  
**AI-driven solution**

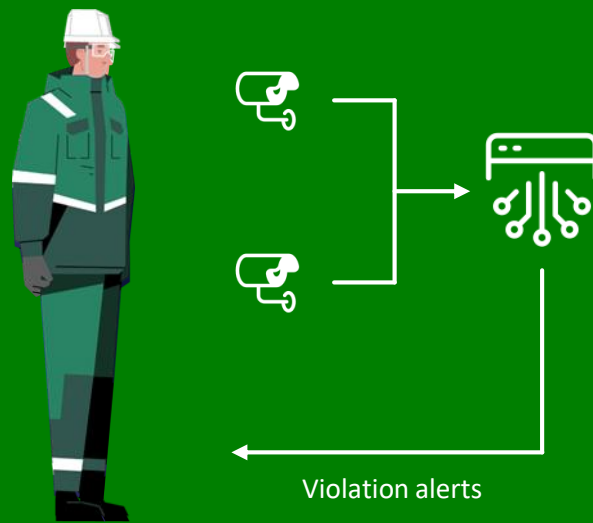

Outcome and effects:

**Automated work oversight for precise HSE monitoring and efficiency**

- Increasing the coverage of independent oversight from under 1% to **100%**
- Ensuring **24/7** coverage of all works
- Gaining information that enables an **objective view** of performance
- Driving **systematic and immediate** actions within personnel interventions

# NVI Solutions AI-driven video analytics platform for marine safety

Key technology for effective management of violations and personnel



## Camera

The camera continuously records what is happening on the site



## Artificial intelligence

Continuously analyzes the video stream in real time: compares the current situation with predefined safe behavior patterns



## Alarm signal / Alert

Notifying the worker about unsafe work execution via loudspeaker



## Notification

Notifying the person responsible for safe work execution about the detected violation

**Video analysis for violations**

23.03.2026 - 14:35:02	✓
23.03.2026 - 14:35:03	✓
23.03.2026 - 14:35:04	✗

A worker is detected without PPE

d5e020f1a4a3

Event  
Person without PPE

Place	Time
Vessel	13.08.2024 13:52:59

Video  
All Cameras  
camera №202

Mode  
Regular work

Comment

# NVI Solutions AI-driven video analytics platform for marine safety

From violations detection to corrective actions

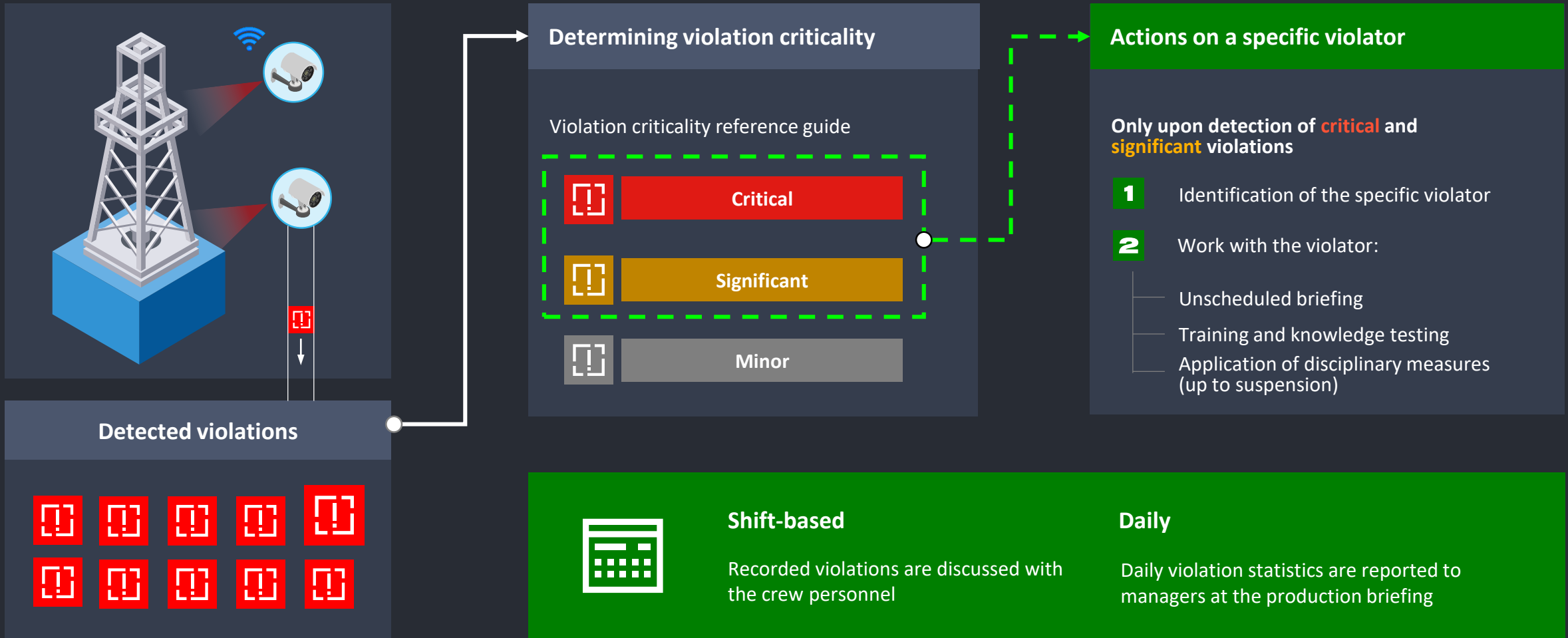

# AI-driven video analytics in modern safety culture

Using technology for building motivation and managing contractors

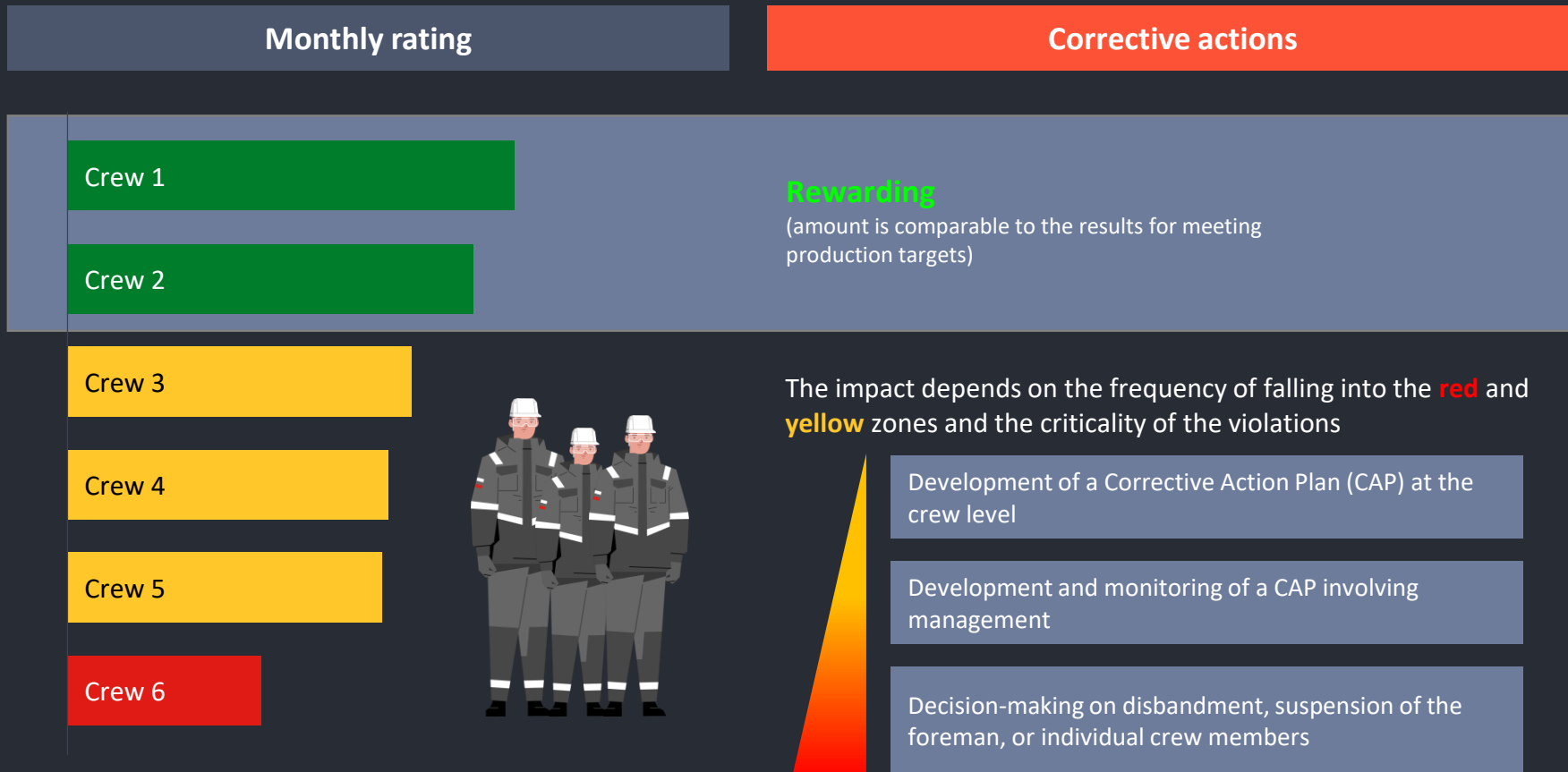

**+**



### Ranking of contractor organizations

Emergence of additional work volumes

- ↳ Contractors in the **green** zone are considered

Need for reduction

- ↳ Contractors in the **red** zone are considered

[ 3 ]



## **NVI Solutions AI-powered video analytics**

Core framework for reaching industrial safety and  
efficiency excellence

# NVI Solutions AI-powered video analytics

The NVI Solutions product as a digital, highly experienced operator or supervisor

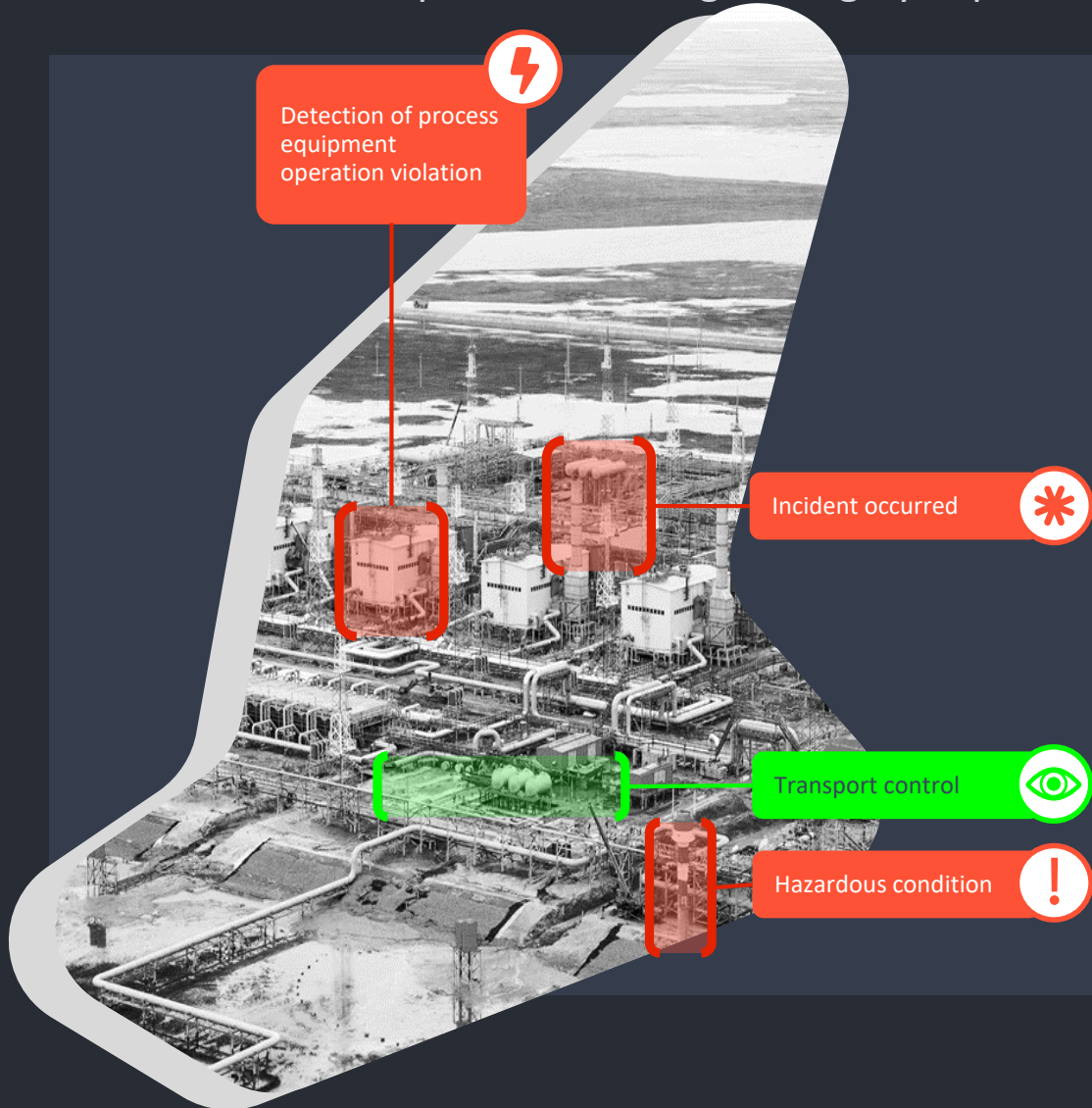

**01** Operates effectively under **real conditions of industrial production** with vibrations, obstacles, and poor visibility

**02** Works alongside everyone — right at the facility, keeping **all data under full control**

**03** Recognizes **complex situations** occurring on the enterprise premises

**04** **Sees everything** that happens at the production site in real time and with high detail

**05** Has high computational performance and scalability, **does not require massive processing power**

**06** **Can connect to other production systems** to expand technological capabilities within the framework of facility digitalization

# NVI Solutions AI-powered video analytics

Software. Popular basic recognition classifiers for complex scenarios and tasks

## Personnel

- Presence / absence of a person
- People counting
- Body parts
- Body postures
- Typical / atypical actions
- Fingerprinting by QR codes

## Transport

- Cars
- Trucks
- Trains
- Vessels
- Forklifts
- Cranes
- Special vehicles
- License plates
- Movement direction
- Route / trajectory tracking

## PPE

- Hard hat
- Safety goggles
- Respirator
- Face shield
- Face mask
- Protective jacket
- Protective trousers
- High-visibility / reflective vest
- Gloves
- Safety harness (fall protection system)
- Bare forearms
- Hood

## Work types

- Hot works
- Gas-hazardous work
- Lifting operations
- Works at height
- Pressure work

## Zones / areas

- Work zones
- Equipment operation zones
- Perimeter
- Entry / exit zones
- Public areas
- Crossing lanes

## Equipment

- Equipment
- Parts / components
- Location
- Orientation
- Shape changes

## Anomalies

- Fire
- Smoke
- Steam
- Leakages

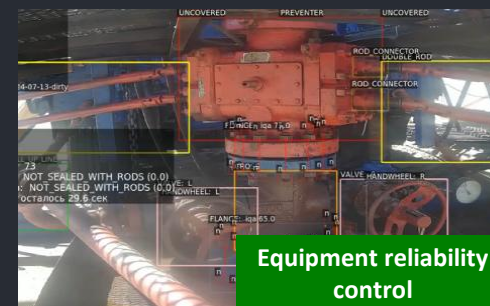
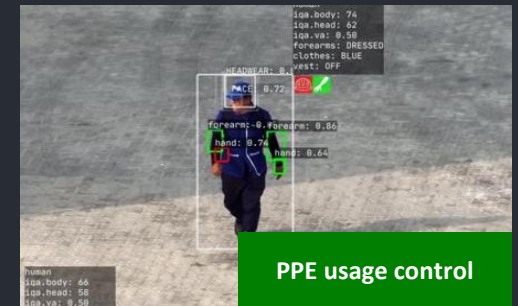

# NVI Solutions AI-powered video analytics

Software. Example of complex uses cases composition



Example:

**Detection of a person in the danger zone under a load during loading/unloading operations**

Scenario logic:

1. Searching for vehicles, crane booms, hooks
2. Determining boom direction and associating the «vehicle-boom» crane pair
3. Localizing the zone to search for cones, recognizing cones
4. Building a potential danger zone under the crane based on the detected objects
5. Determining the fact that loading/unloading operations are currently taking place
6. Recognizing people and checking if a person is in the danger zone

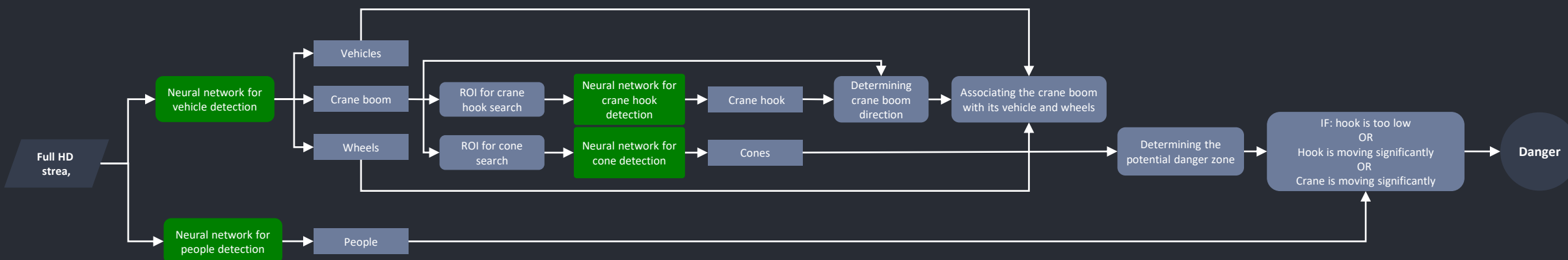

# NVI Solutions AI-powered video analytics

Software. Areas of technology impact on production efficiency and safety – more than 250 use cases

## HSE compliance

### Scenario examples:

- A person has climbed to a height of more than 1.8 meters without a safety harness
- An employee is leaning over the handrails
- Detection of people in the danger zone on the walkway during pipe lowering and lifting
- A person is located closer than 2 meters from the edge of the rotary table

### Performance metrics:

- Improved quality of rounds / supervision control
- Reduction in the number of HSE incidents
- Reduction in FAR, AAR, LTIF injury accident rates (LTIF relates to the lost time injury frequency)

## Operational efficiency

### Scenario examples:

- Registration of personnel movements across the site
- Determining the presence / absence of personnel and people counting
- Access control of unauthorized persons to operating equipment
- Vehicle control at the checkpoint
- Monitoring the sequence of technological operations during maintenance work

### Performance metrics:

- Reduction in operational costs (OPEX)
- Optimization of inefficient processes
- More efficient use of human and technical resources

## Equipment monitoring

### Scenario examples:

- Identification / recognition of equipment and its components
- Determining the position of equipment elements and assemblies
- Detection of sparking, critical heating, destruction, or fire of equipment
- Detection of valve and pipeline leaks

### Performance metrics:

- Reduction in equipment repair time and costs through rapid incident detection
- Reduction of losses and environmental risks due to decreased incident detection and response time

# NVI Solutions AI-powered video analytics

Software. Examples of ready-to-deploy complex scenarios – industrial safety and compliance

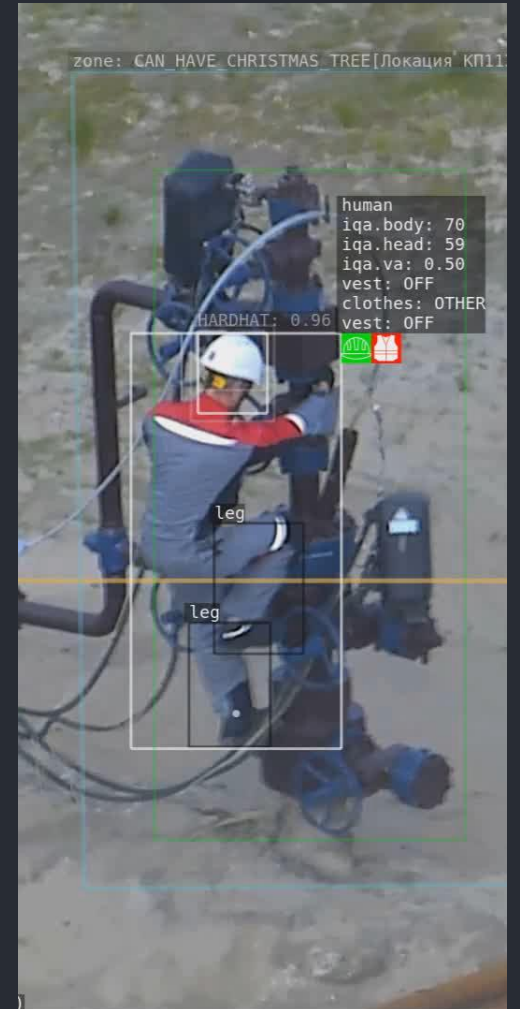
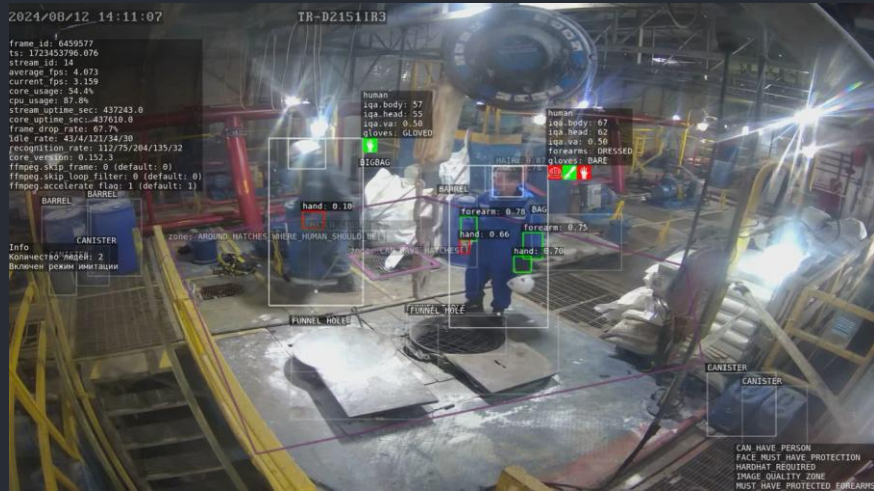



# NVI Solutions AI-powered video analytics

Software. Web-based platform for monitoring and event control

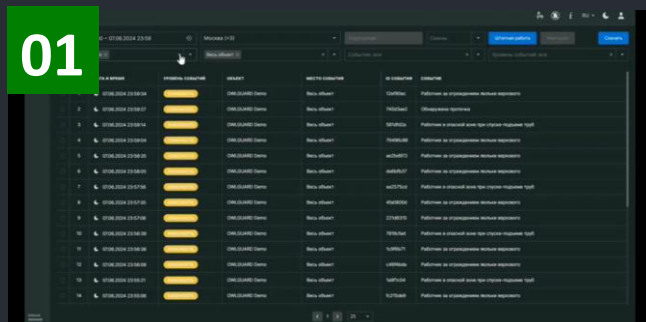

## Monitoring and management platform

Allows for easy supervision of operations at one or multiple production facilities, with a special focus on key performance indicators (KPIs)

### Key features:

- Easy-to-use interface
- 24/7/365 monitoring and management
- Real-time pop-up and email notifications
- Event validation functionality for supervisors and administrators
- Regular reports for responsible employees
- Report frequency customization feature
- Information panels with dashboards
- Advanced customizable statistics
- Event log with adaptive filters and a search system
- Ability to upload archived video to search for violations
- Integration capabilities with VMS, SCADA and IoT systems
- Ability to work with video walls in operation control centers

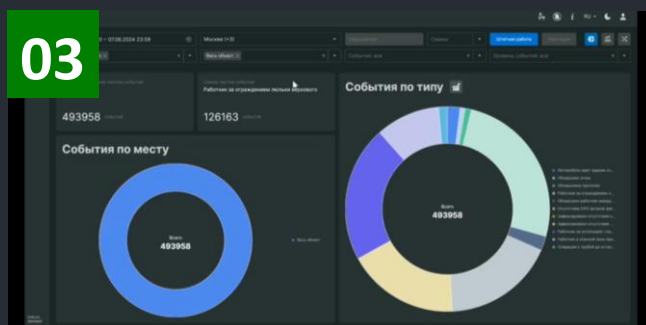
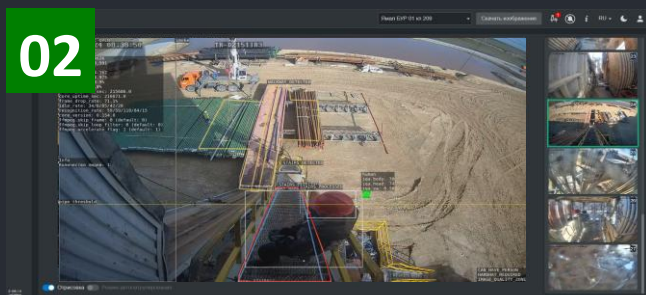

# NVI Solutions AI-powered video analytics

Hardware. Functional diagram of typical solution deployment for real-time edge AI analytics



# NVI Solutions AI-powered video analytics

Hardware. Edge AI infrastructure concept – facility level

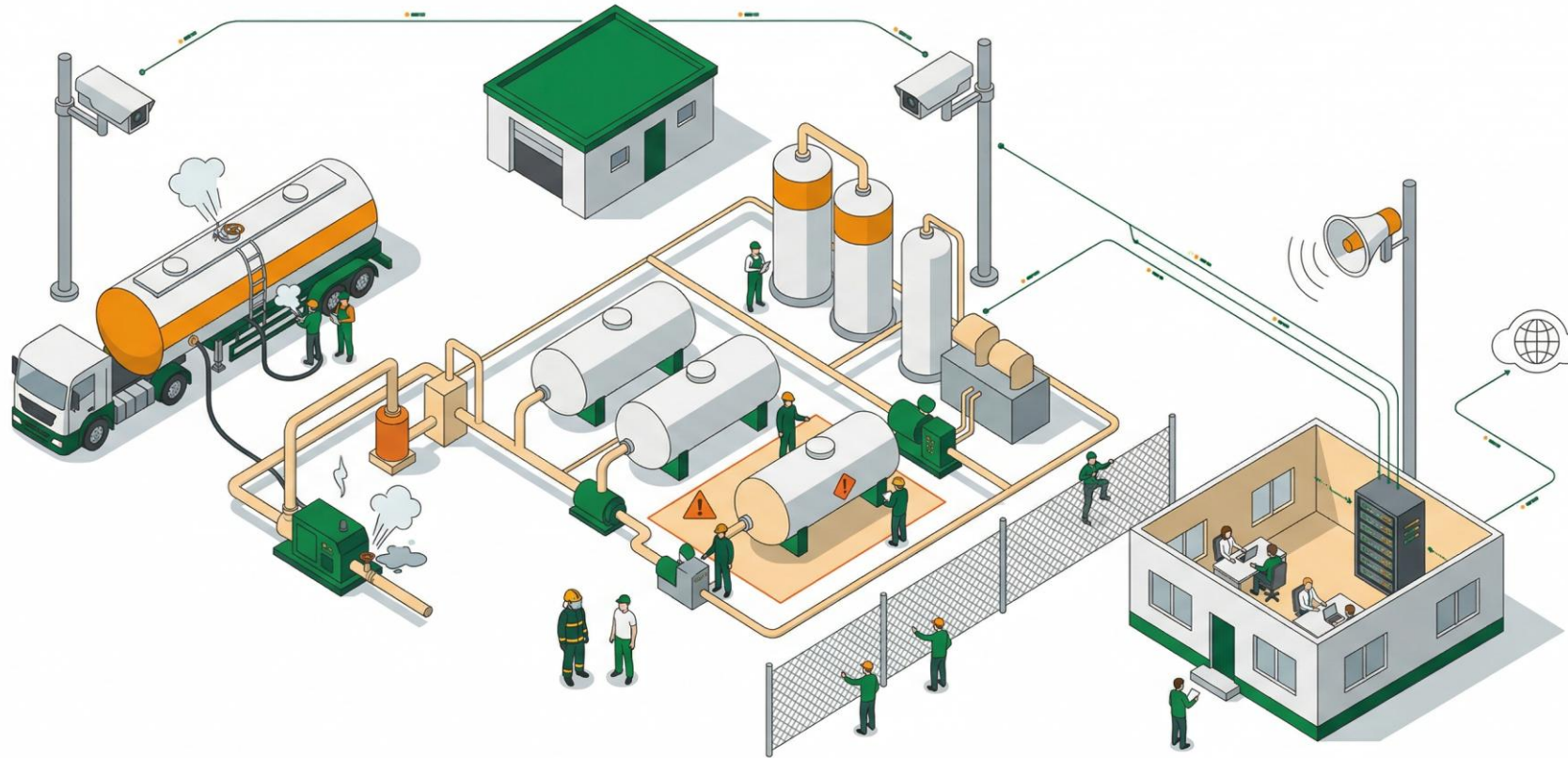

# NVI Solutions AI-powered video analytics

Hardware. Edge AI infrastructure concept – centralized video analytics facility coverage

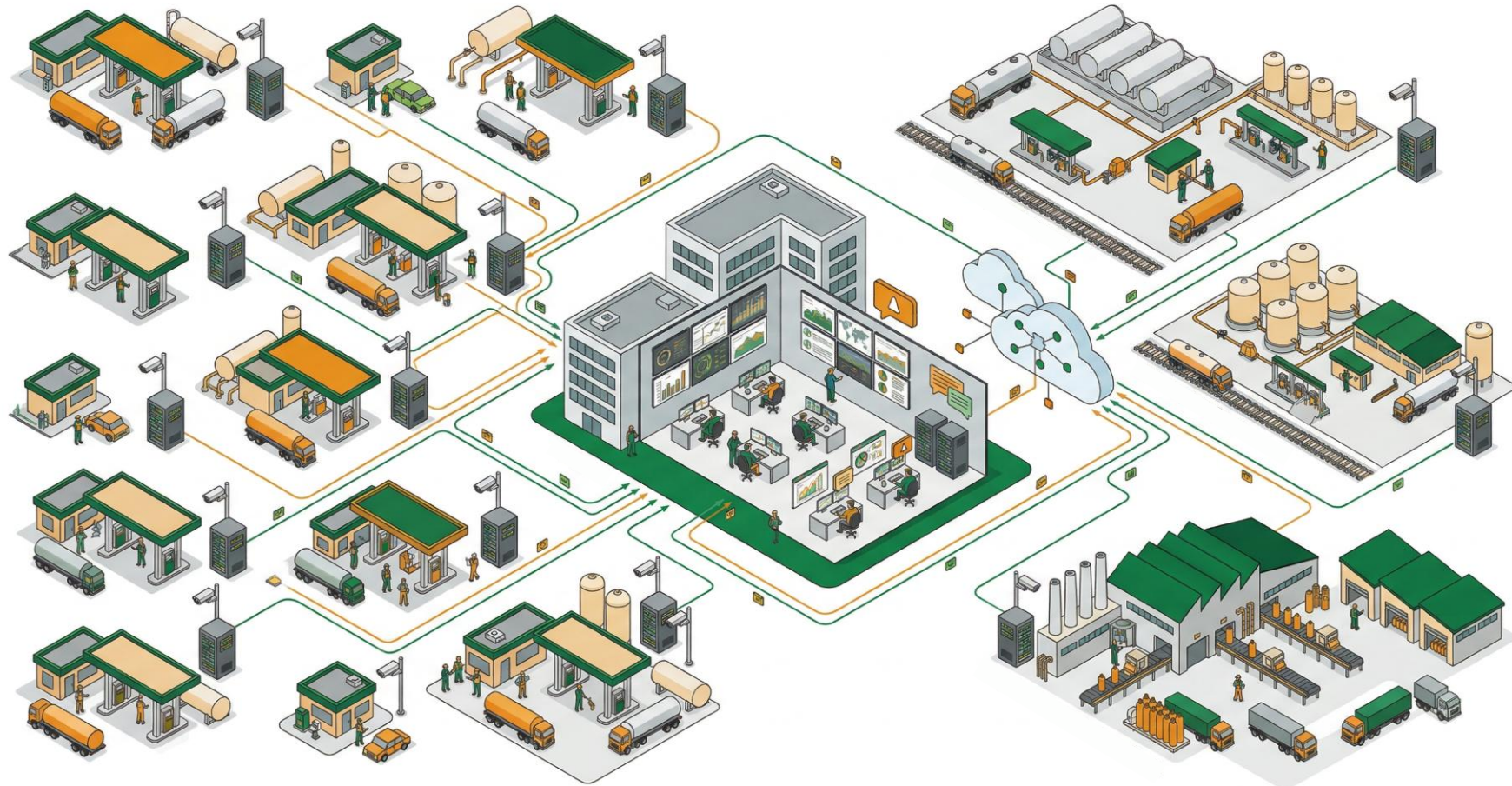

# NVI Solutions AI-powered video analytics

Hardware. Mobile video analytics equipment for special workplaces

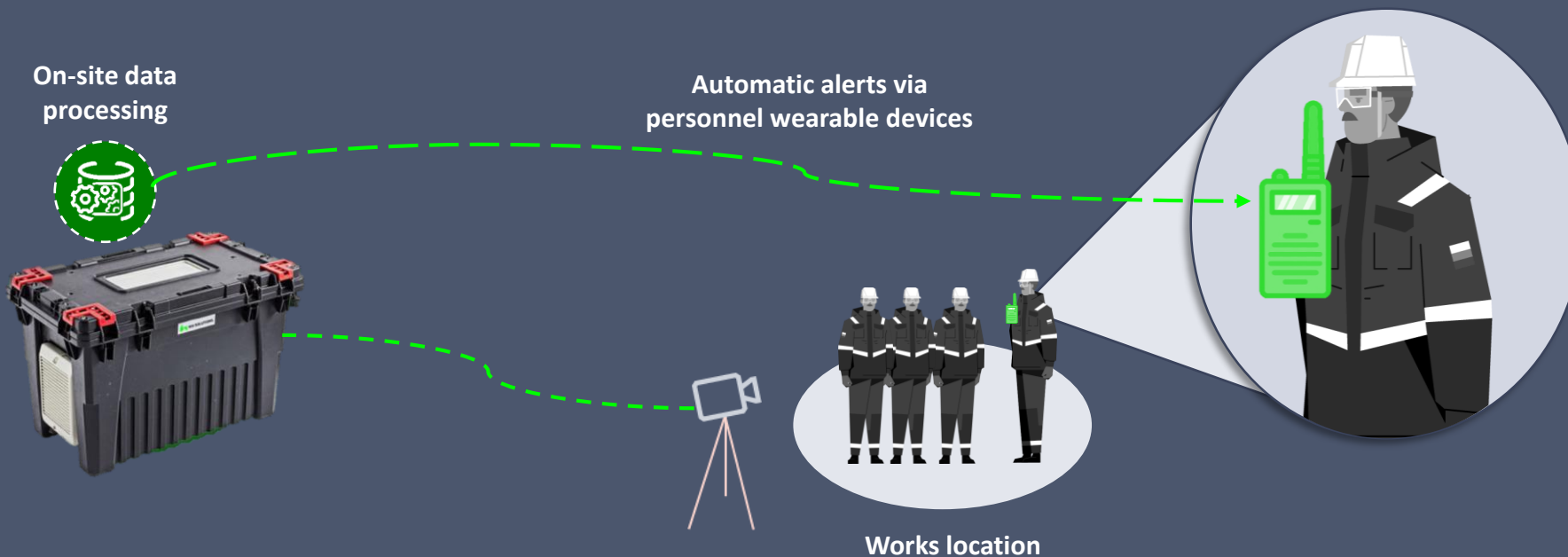

Can be used at work places where long-distance data transfer is not possible

## High edge computing ability

- Up to **8 cameras** and **17 use cases** running simultaneously

## Autonomous UPS option

- Stable operation and video analytics **from 8 to 12 hours**

## Climate zones variety

- Stable operation in temperature range **from -40°C до +30°C**

# NVI Solutions AI-powered video analytics

Functional diagram of typical solution deployment for real-time analytics



## Implementation duration

**~18 days**

from the moment of equipment delivery

Delivery of equipment to the warehouse

Equipment installation and configuration

System installation and configuration

Dataset collection and system adaptation

Acceptance tests (SAT)

Handover of the system into operation

System optimization

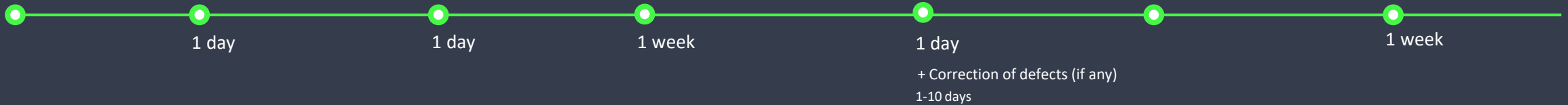

# NVI Solutions AI-powered video analytics

Hybrid retrospective video analytics service: concept and types of delivery

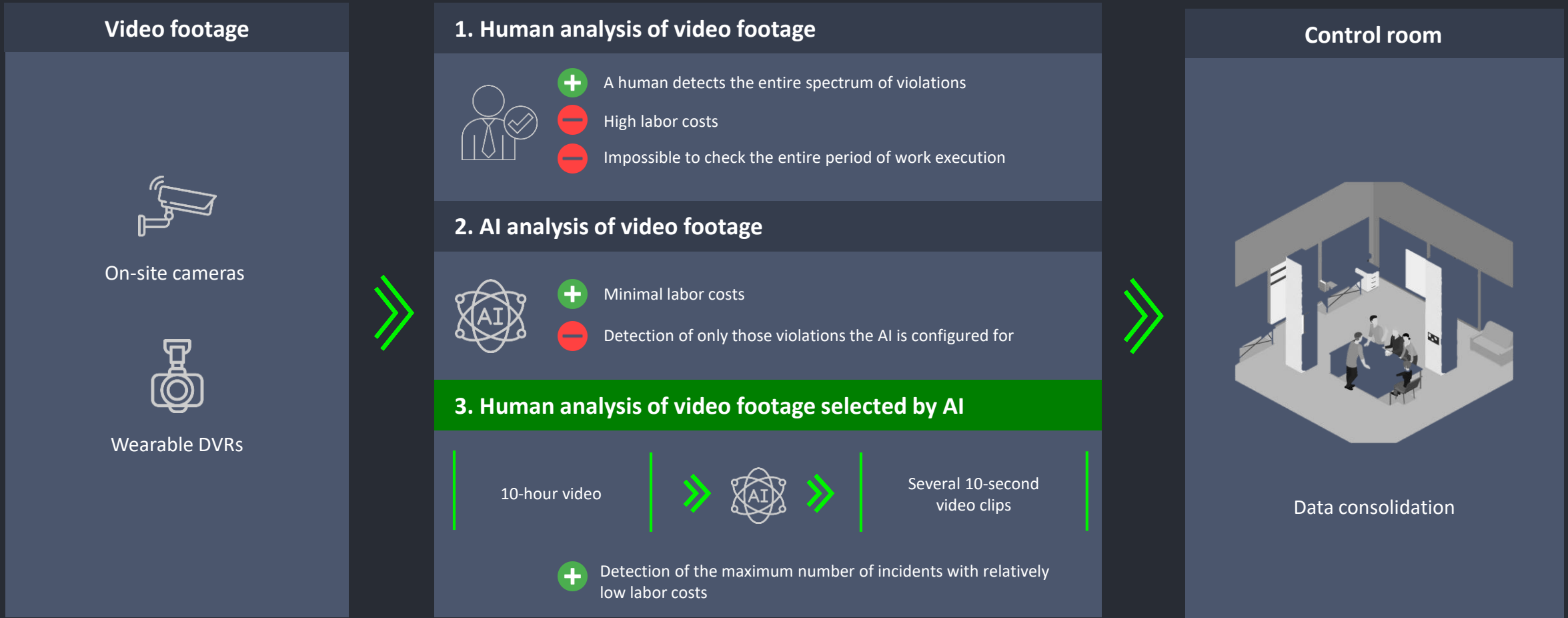

# NVI Solutions AI-powered video analytics

Hybrid retrospective video analytics service: example of customer interactive dashboard

## HRW dashboard – Location 52

HRW works duration  
**4.4 h**

Average head count in frame  
**5 persons**

Supervisor presence rate  
**55%**

Video coverage rate  
**71%**

Safety violations  
**5**

### Process control

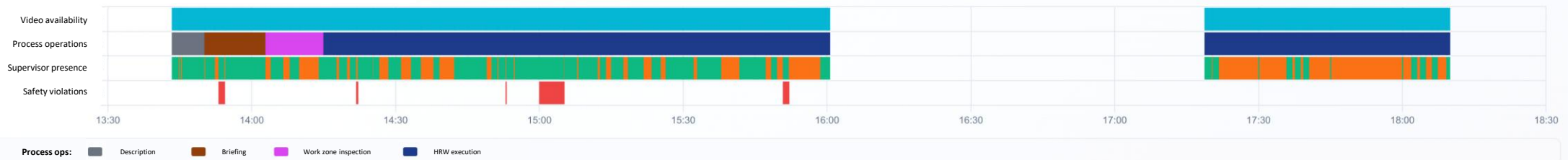

### Crew composition control



[ 4 ]



## NVI Solutions pre-designed products for oil & gas

Productified CV technology bundles for oil & gas market





# NVI Solutions pre-designed products for oil & gas

Productified CV technology bundles for oil & gas market

Application	DRILLING	WORKOVER	WELLPADS	TRANSPORT	SURFACE	OFFSHORE	R&D
							
Status and product	Product scaling	Product scaling	Product scaling	Product scaling	Ready for product scaling	Ready for product scaling	<ul style="list-style-type: none"> <li>• Industrial high-risk operations</li> <li>• Construction areas</li> <li>• Underwater operations</li> <li>• Warehouses</li> <li>• Mining areas</li> <li>• Non-production time calculation</li> <li>• Autonomous operations</li> <li>• Drone operations</li> </ul>
	<b>owl.Drill</b> video analytics in drilling	<b>owl.Workover</b> video analytics in well workover and intervention	<b>owl.Wellpad</b> video analytics on wellpads	In-cabin video analytics for transport	Video analytics for surface facilities	Video analytics for offshore facilities	
Installations	150 drilling rigs	270 workover crews	80 wellpads	5 000 vehicles	3 surface facilities	3 offshore platforms	

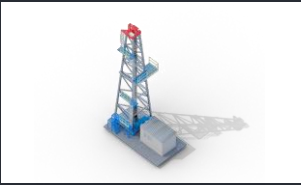
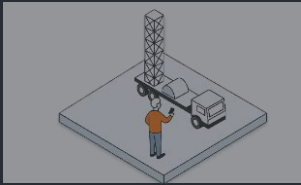
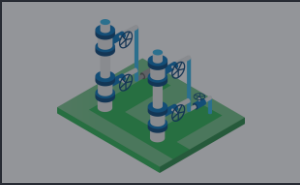
# NVI Solutions pre-designed products for oil & gas

Productified CV technology bundles for oil & gas market

Application	DRILLING	WORKOVER	WELLPADS	TRANSPORT	SURFACE	OFFSHORE	R&D
							
Status and product	Product scaling	Product scaling	Product scaling	Product scaling	Ready for product scaling	Ready for product scaling	<ul style="list-style-type: none"> <li>• Industrial high-risk operations</li> <li>• Construction areas</li> <li>• Underwater operations</li> <li>• Warehouses</li> <li>• Mining areas</li> <li>• Non-production time calculation</li> <li>• Autonomous operations</li> <li>• Drone operations</li> </ul>
	<b>owl.Drill</b> video analytics in drilling	<b>owl.Workover</b> video analytics in well workover and intervention	<b>owl.Wellpad</b> video analytics on wellpads	In-cabin video analytics for transport	Video analytics for surface facilities	Video analytics for offshore facilities	
Installations	150 drilling rigs	270 workover crews	80 wellpads	5 000 vehicles	3 surface facilities	3 offshore platforms	

# NVI Solutions pre-designed products for oil & gas

owl.Drill video analytics in drilling. Concept



Equipment for control

17 cameras

Control of work zones:

General overview, rig floor, wellhead, derrickman's monkey board, driller

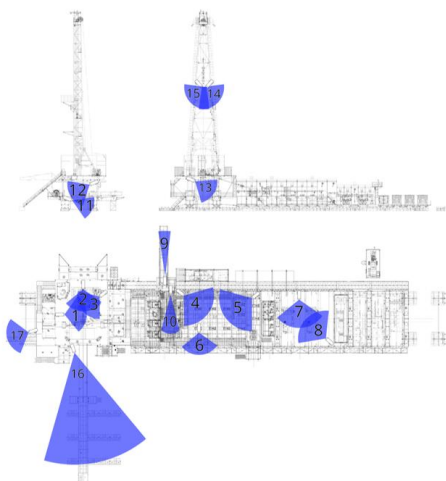

36 detectors for:

- Presence and actions of personnel;
- Danger zones;
- Location and operation of equipment



Automatic detection

24 complete scenarios

As a result of real-time video stream analysis the following are detected:

- Exceeding the maximum allowable speeds for running and pulling pipes (tripping operations)
- Dismantling of blowout preventer (BOP) equipment before the completion of well cementing
- Performing repairs with open covers and the screw conveyor motor turned on
- Working at a height of 1.8 m and above without a safety harness

And other unsafe acts / unsafe conditions

Risk minimization



- Oil, gas, and water kicks
- Falls while working at height
- Being in a falling object



Personnel informing via

Loudspeaker

Upon system trigger:

Instant violation notification via loudspeaker and in the system

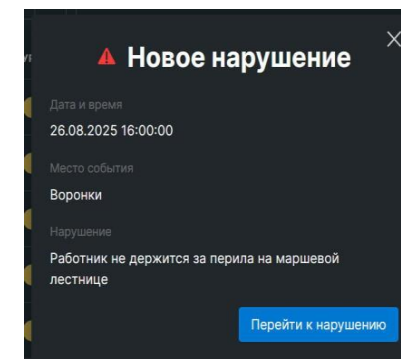

The system automatically generates and sends a violation report to the responsible persons

Report generation



The system automatically generates and sends a violation report to the responsible persons

# NVI Solutions pre-designed products for oil & gas

owl.Drill video analytics in drilling. Equipment

Camera layout scheme

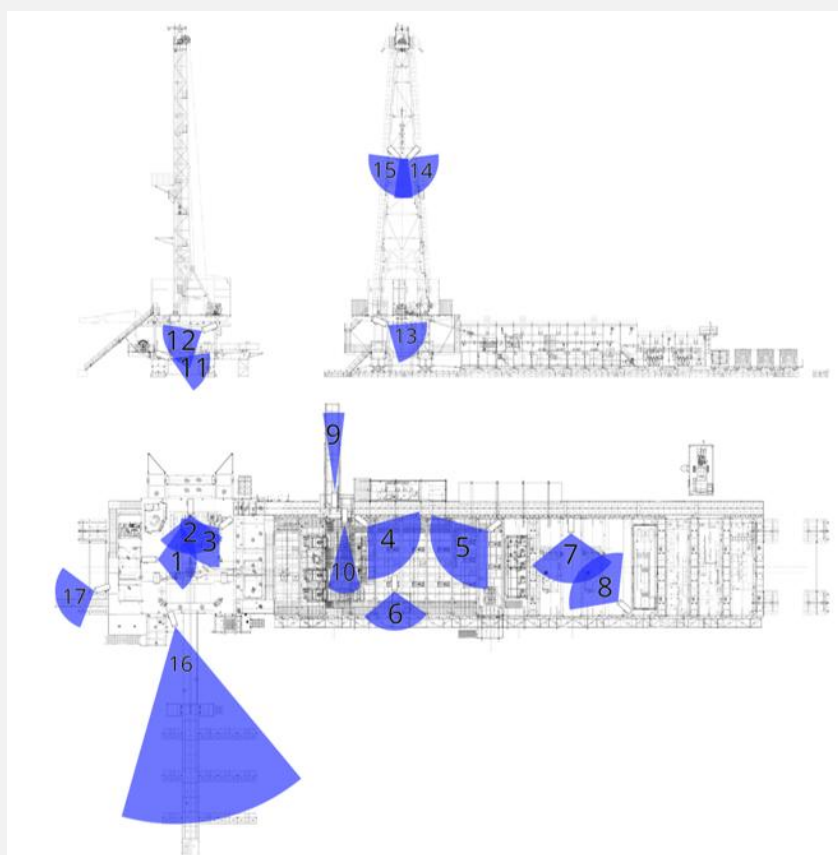

Equipment connection diagram

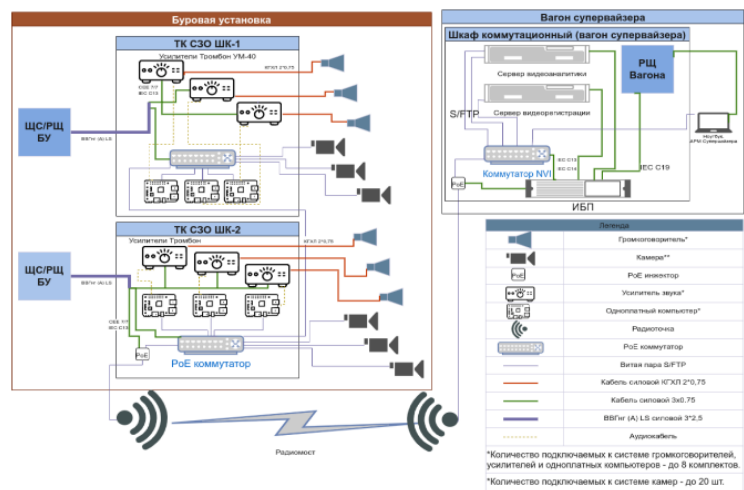

Technical requirements for video streams

- Frame rate – constant, at least 15 fps
- Frame size – 1920\*1080, Full HD standard
- Compression algorithm – H.265 (preferred), H.264
- Video stream bit rate – 3 Mbps per stream
- Viewing access – via RTSP protocol

Equipment for 1 drilling rig

№	Item / Description	Q-ty
<b>1</b>	<b>Video analytics cabinet (in the trailer camp)</b>	<b>1</b>
1.1	Server	1
1.2	UPS	1
1.3	PoE switch	1
1.4	Climate-controlled server cabinet	1
1.5	Materials, components	1
<b>2</b>	<b>Sound/communication cabinet (on the drilling rig)</b>	<b>2</b>
2.1	PoE switch	3
2.2	RaspberryPi	4
2.3	Audio amplifier	4
2.4	Climate-controlled cabinet	2
<b>3</b>	<b>Cameras, PA system (on the drilling rig)</b>	<b>1</b>
3.1	Camera	17
3.2	Explosion-proof speaker	8
3.3	Wireless bridge	2
3.4	Mikrotik SXT LTE6 kit	1
<b>4</b>	<b>Operator workstation - PC</b>	<b>2</b>
<b>5</b>	<b>Installation materials</b>	<b>1</b>

# NVI Solutions pre-designed products for oil & gas

owl.Drill video analytics in drilling. Effects

## Average daily number of violations per crew (6 crews)

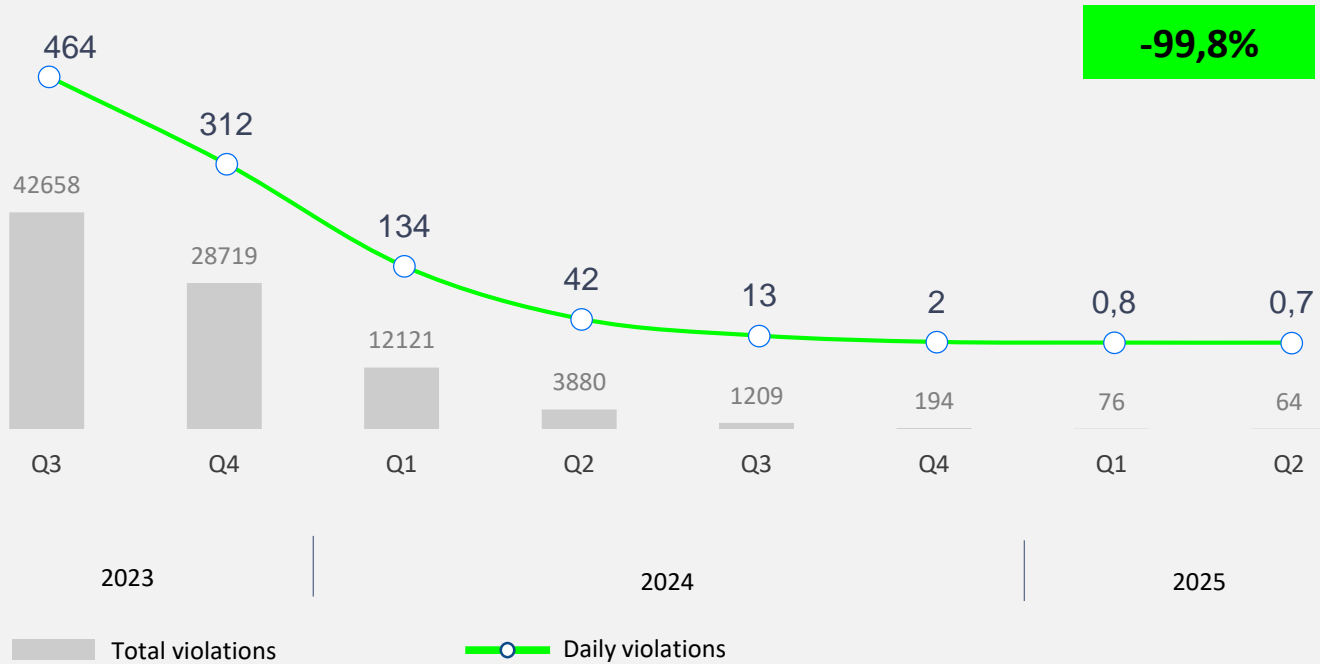





The total number of violations decreased by more than

**600 times**

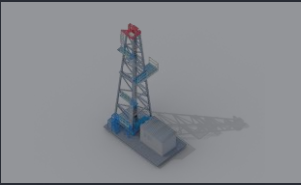
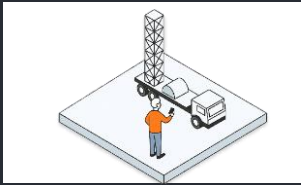
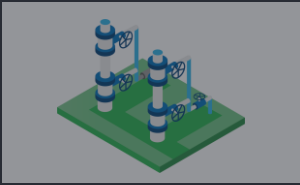
# NVI Solutions pre-designed products for oil & gas

Productified CV technology bundles for oil & gas market

Application	DRILLING	WORKOVER	WELLPADS	TRANSPORT	SURFACE	OFFSHORE	R&D
							
Status and product	Product scaling	Product scaling	Product scaling	Product scaling	Ready for product scaling	Ready for product scaling	<ul style="list-style-type: none"> <li>• Industrial high-risk operations</li> <li>• Construction areas</li> <li>• Underwater operations</li> <li>• Warehouses</li> <li>• Mining areas</li> <li>• Non-production time calculation</li> <li>• Autonomous operations</li> <li>• Drone operations</li> </ul>
	<b>owl.Drill</b> video analytics in drilling	<b>owl.Workover</b> video analytics in well workover and intervention	<b>owl.Wellpad</b> video analytics on wellpads	In-cabin video analytics for transport	Video analytics for surface facilities	Video analytics for offshore facilities	
Installations	150 drilling rigs	270 workover crews	80 wellpads	5 000 vehicles	3 surface facilities	3 offshore platforms	

# NVI Solutions pre-designed products for oil & gas

owl.Workover video analytics in well workover and intervention. Concept



Equipment for control

5-6 cameras

Control of work zones:

General overview, rig floor, wellhead, derrickman's monkey board, driller

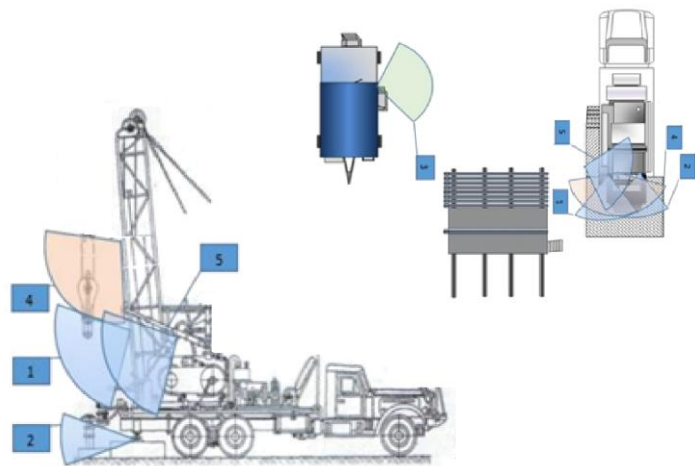

28 detectors for:

- Presence and actions of personnel;
- Danger zones;
- Location and operation of equipment



Automatic detection

19 complete scenarios

As a result of real-time video stream analysis  
**the following are detected:**

- Absence of crew personnel at the wellhead of an unsealed well
- Presence of a kick or overflow from the well
- Performing work without installed blowout preventer (BOP) equipment
- A worker being under a moving (suspended) load
- Working at a height of 1.8 m and above without a safety harness

And other unsafe acts / unsafe conditions

**Risk minimization**



- Oil, gas, and water kicks
- Falls while working at height
- Being in a falling object



Personnel informing via

Loudspeaker

Upon system trigger:

**Instant violation notification via loudspeaker and in the system**

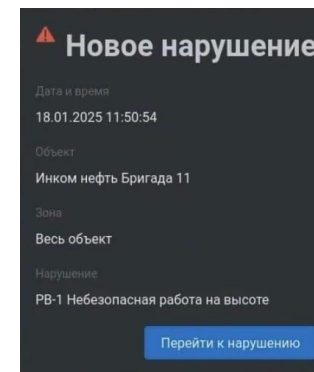

**The system** automatically generates and sends a violation report to the responsible persons

**Report generation**



The system automatically generates and sends a violation report to the responsible persons

# NVI Solutions pre-designed products for oil & gas

owl.Workover video analytics in well workover and intervention. Equipment

### Control of work zones at the workover facility

**1 – Rig floor**

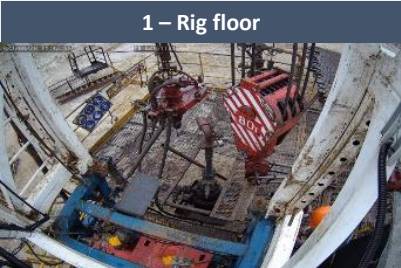

**2 – Wellhead**



**3 – Overview camera**





**4 – 360° camera on the mast**



**5 – Driller's workstation**



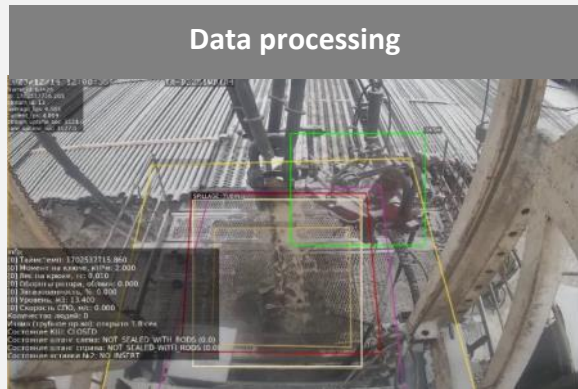

Real-time video stream analysis on the local video analytics server at the facility

Detection of violations in accordance with the algorithms of developed markers and scenarios

The delay between repeated triggers for a similar violation is 3-5 minutes. It is configured at the Customer's discretion

The system is capable of processing several different simultaneous or sequential violations without delay

### System triggering

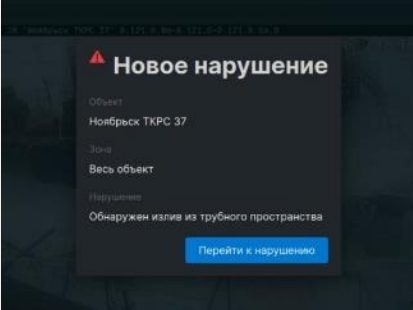



Real-time audio notification for employees who committed a violation at the facility

Information message at the supervisor's workstation

Correction of employee behavior patterns

### Report generation

The system automatically generates and sends a violation report to the responsible persons

Sending the report to the customer

# NVI Solutions pre-designed products for oil & gas

owl.Workover video analytics in well workover and intervention. Effects

## Average daily number of violations per crew (2 crews)

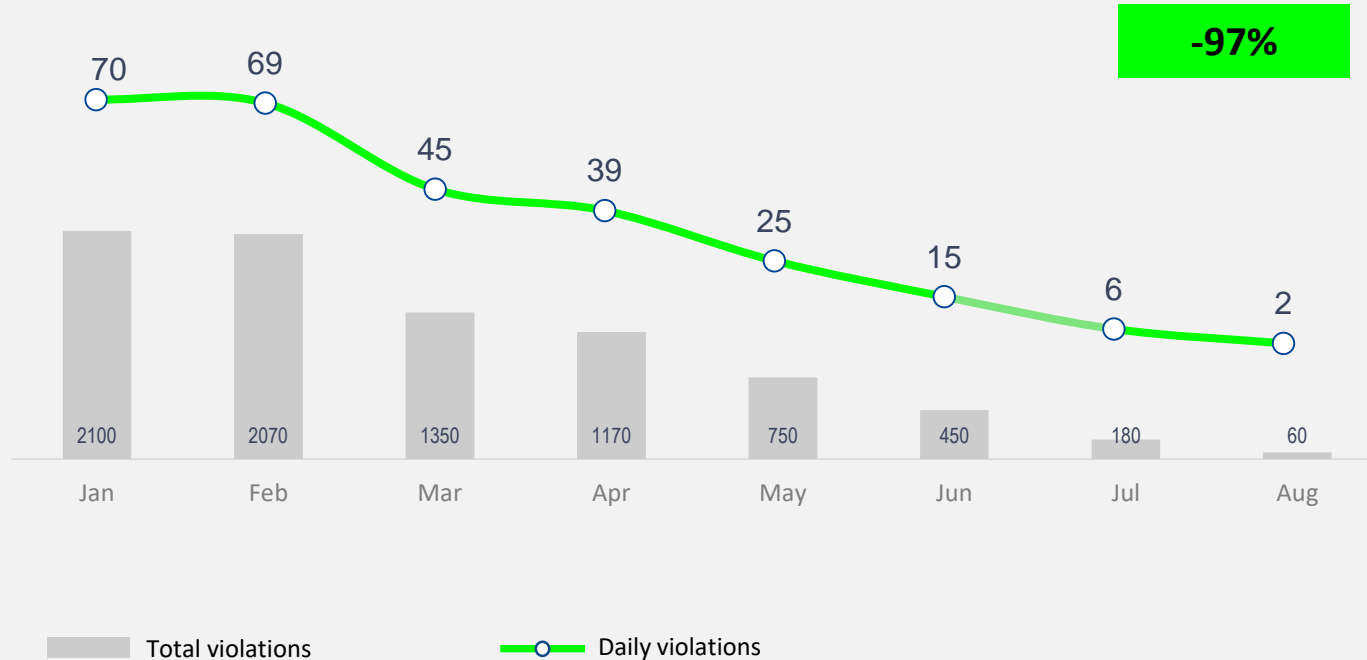

The total number of violations decreased by more than





**35 times**

including severe ones -

**70 times**

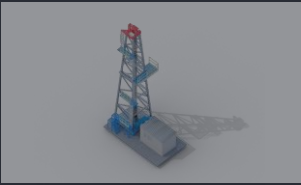
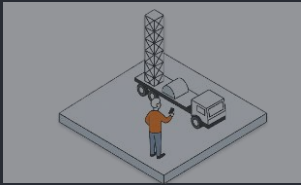
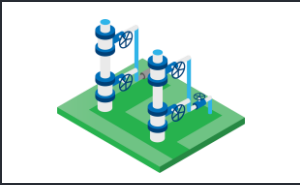
# NVI Solutions pre-designed products for oil & gas

Productified CV technology bundles for oil & gas market

Application	DRILLING	WORKOVER	WELLPADS	TRANSPORT	SURFACE	OFFSHORE	R&D
							
Status and product	Product scaling	Product scaling	Product scaling	Product scaling	Ready for product scaling	Ready for product scaling	<ul style="list-style-type: none"> <li>• Industrial high-risk operations</li> <li>• Construction areas</li> <li>• Underwater operations</li> <li>• Warehouses</li> <li>• Mining areas</li> <li>• Non-production time calculation</li> <li>• Autonomous operations</li> <li>• Drone operations</li> </ul>
	<b>owl.Drill</b> video analytics in drilling	<b>owl.Workover</b> video analytics in well workover and intervention	<b>owl.Wellpad</b> video analytics on wellpads	In-cabin video analytics for transport	Video analytics for surface facilities	Video analytics for offshore facilities	
Installations	150 drilling rigs	270 workover crews	80 wellpads	5 000 vehicles	3 surface facilities	3 offshore platforms	

# NVI Solutions pre-designed products for oil & gas

owl.Wellpad video analytics on wellpads. Concept



Equipment for control  
from 2 cameras

Control of work zones:

**General overview, site, Automated Group Metering Unit (AGMU), manifold block**



**28 detectors for:**

- Presence and actions of personnel;
- Danger zones;
- Location and operation of equipment



Automatic detection  
14 complete scenarios

As a result of real-time video stream analysis  
**the following are detected:**

- Detection of people appearing on the site, identification of the work zone according to a pre-defined list of zones
- Safe distance of special equipment from the work site and danger zones during hot work
- Detection of fire and smoke anywhere on wellpad
- Monitoring of water leaks in the chemical injection unit by indirect signs (presence of steam around the unit)

And other unsafe acts / unsafe conditions

**Risk minimization**



- Depressurization of process equipment
- Falls while working at height
- Being in a falling object zone



Personnel informing via  
Loudspeaker

Upon system trigger:

**Instant violation notification via loudspeaker and in the system**

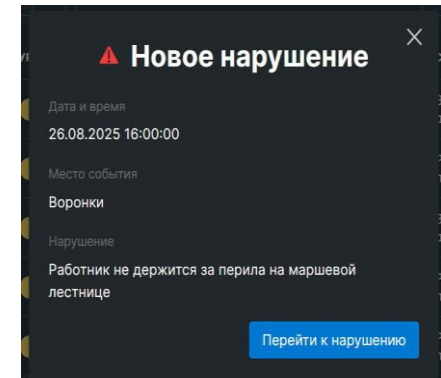

**The system** automatically generates and sends a violation report to the responsible persons

**Report generation**







The system automatically generates and sends a violation report to the responsible persons

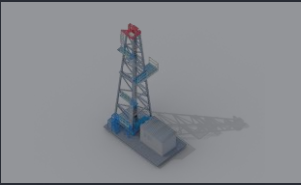
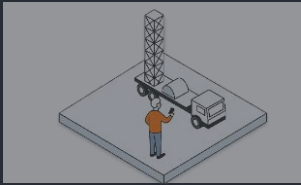
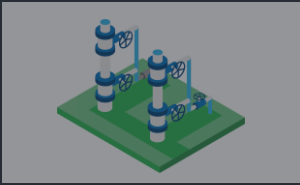

# NVI Solutions pre-designed products for oil & gas

Productified CV technology bundles for oil & gas market

Application	DRILLING	WORKOVER	WELLPADS	TRANSPORT	SURFACE	OFFSHORE	R&D
							
Status and product	Product scaling	Product scaling	Product scaling	Product scaling	Ready for product scaling	Ready for product scaling	<ul style="list-style-type: none"> <li>• Industrial high-risk operations</li> <li>• Construction areas</li> <li>• Underwater operations</li> <li>• Warehouses</li> <li>• Mining areas</li> <li>• Non-production time calculation</li> <li>• Autonomous operations</li> <li>• Drone operations</li> </ul>
	<b>owl.Drill</b> video analytics in drilling	<b>owl.Workover</b> video analytics in well workover and intervention	<b>owl.Wellpad</b> video analytics on wellpads	In-cabin video analytics for transport	Video analytics for surface facilities	Video analytics for offshore facilities	
Installations	150 drilling rigs	270 workover crews	80 wellpads	5 000 vehicles	3 surface facilities	3 offshore platforms	

# NVI Solutions pre-designed products for oil & gas

In-cabin video analytics for transport. Concept



Equipment for control

**3 cameras**

Control of work zones:

**AHD video camera in the driver's cabin (overview)**

**DMS (Driver Monitoring System) video camera for driver fatigue monitoring**

**Front-facing dash camera**



**14 detectors for:**

- Presence and actions of the driver;
- Dangerous maneuvers;
- Driver's condition



Automatic detection

**10 complete scenarios**

As a result of real-time video stream analysis  
**the following are detected:**

- Driver's pupil tracking
- Detection of smoking while driving
- Detection of mobile phone usage
- Distraction from the road
- Dangerous approach
- Forward collision warning
- Pedestrian detection

And other unsafe acts / unsafe conditions

**Risk minimization**



- Driver falling asleep
- Vehicle accidents
- Sabotage



Personnel informing via

**Loudspeaker**

Upon system trigger:

**Instant violation notification via loudspeaker and in the system**

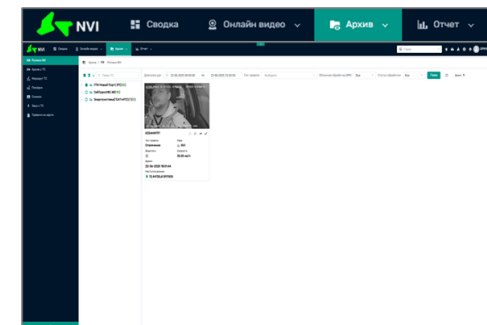

**The system automatically generates and sends a violation report to the responsible persons**

**Report generation**



The system automatically generates and sends a violation report to the responsible persons

# NVI Solutions pre-designed products for oil & gas

In-cabin video analytics for transport. Equipment

For vehicles, the equipment is located directly inside the vehicle. There are no requirements for data transmission channels. Data transmission channels are only needed for sending event notifications.



SHACMAN



Mitsubishi L200



Lonking front-end loader



# NVI Solutions pre-designed products for oil & gas

In-cabin video analytics for transport. Work framework and effects

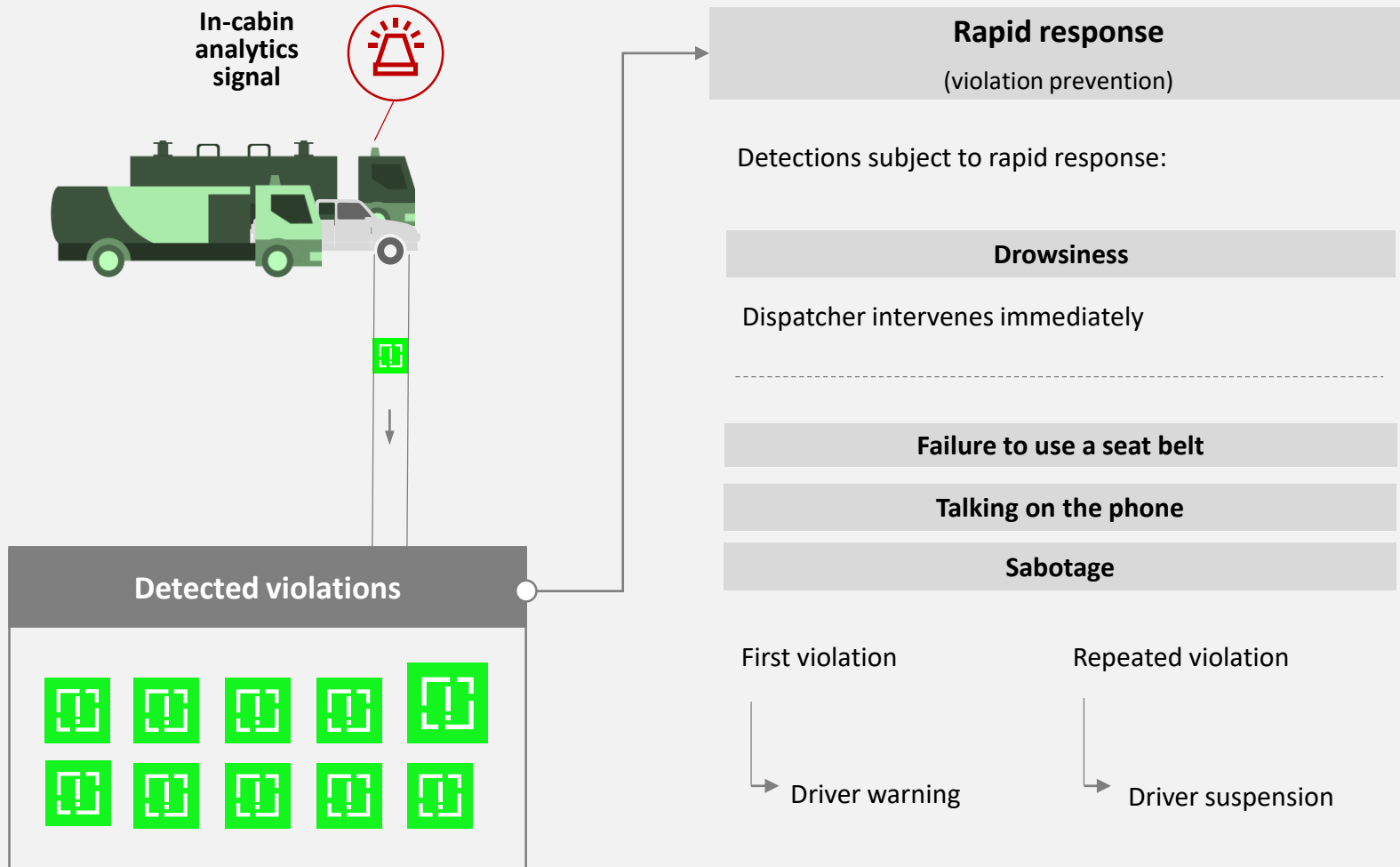





**Over 6 months of 2025:**

Prevented more than **100** instances of falling asleep while driving a vehicle

Stopped more than **800** instances of phone usage while driving a vehicle

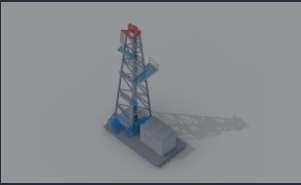
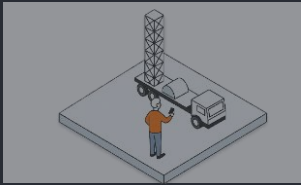
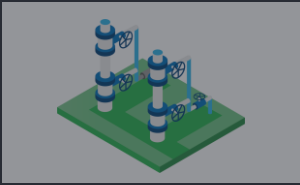
# NVI Solutions pre-designed products for oil & gas

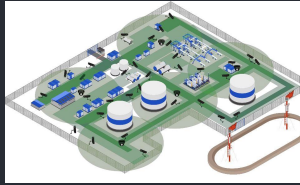
Productified CV technology bundles for oil & gas market

Application	DRILLING	WORKOVER	WELLPADS	TRANSPORT	SURFACE	OFFSHORE	R&D
							
Status and product	Product scaling	Product scaling	Product scaling	Product scaling	Ready for product scaling	Ready for product scaling	<ul style="list-style-type: none"> <li>• Industrial high-risk operations</li> <li>• Construction areas</li> <li>• Underwater operations</li> <li>• Warehouses</li> <li>• Mining areas</li> <li>• Non-production time calculation</li> <li>• Autonomous operations</li> <li>• Drone operations</li> </ul>
	<b>owl.Drill</b> video analytics in drilling	<b>owl.Workover</b> video analytics in well workover and intervention	<b>owl.Wellpad</b> video analytics on wellpads	In-cabin video analytics for transport	Video analytics for surface facilities	Video analytics for offshore facilities	
Installations	150 drilling rigs	270 workover crews	80 wellpads	5 000 vehicles	3 surface facilities	3 offshore platforms	

# NVI Solutions pre-designed products for oil & gas

Video analytics for surface facilities. Concept



Equipment for control  
from 10 cameras

Control of work zones:

**Entrances to modular facilities, main spans, work zones**



**28 detectors for:**

- Presence and actions of personnel;
- Danger zones;
- Location and operation of equipment



Automatic detection  
14 complete scenarios

As a result of real-time video stream analysis  
**the following are detected:**

- Detection of people appearing on the site, identification of the work zone according to a pre-defined list of zones
- Recognition of PPE presence
- Detection of fire and smoke
- Motionless state of a person (или Man down detection)
- Restricted areas
- Oil spill detection

And other unsafe acts / unsafe conditions

**Risk minimization**



- Разгерметизация технологического оборудования
- Падения персонала при работе на высоте
- Гибель человека



Personnel informing via  
**Loudspeaker**

Upon system trigger:

**Instant violation notification via loudspeaker and in the system**

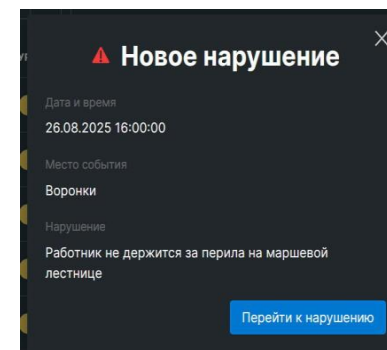

**The system** automatically generates and sends a violation report to the responsible persons

**Report generation**



The system automatically generates and sends a violation report to the responsible persons

# NVI Solutions pre-designed products for oil & gas

Video analytics for surface facilities. Equipment

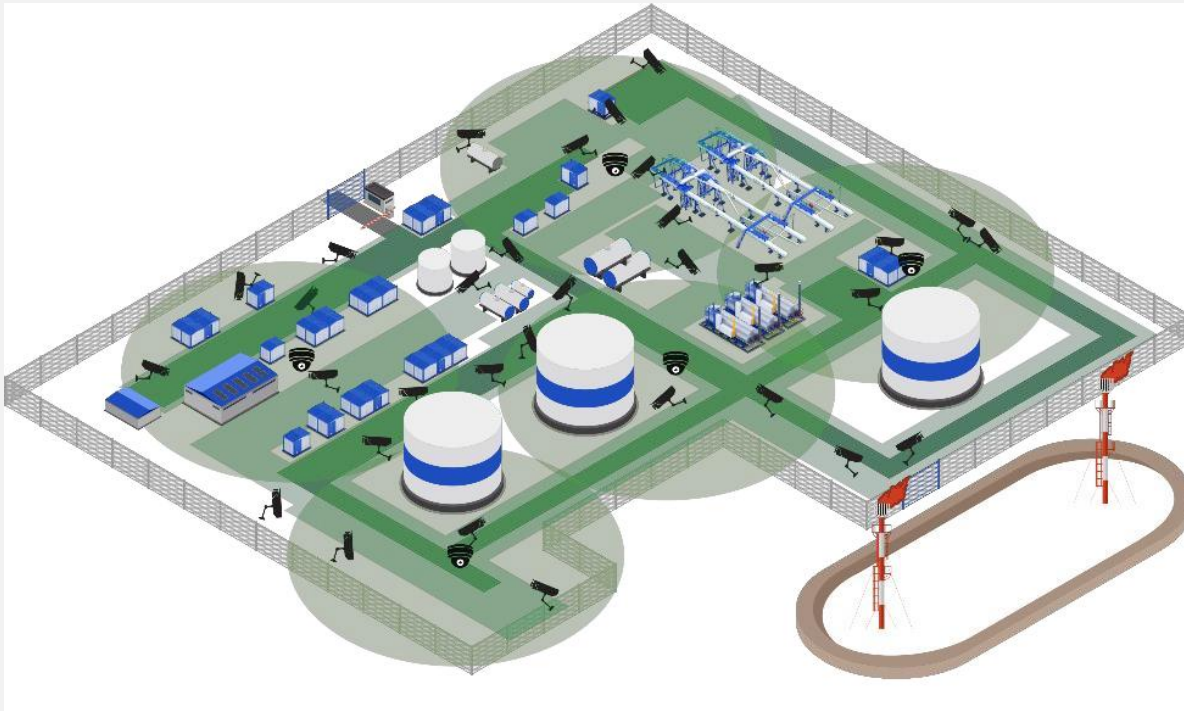





## Standard equipment for facility deployment

- **PTZ cameras** - monitoring of main work zones
- **Directional (fixed) cameras** - monitoring of work zones at specific control points
- **Loudspeaker** - audio notification at the facility
- **Network and server equipment**
  - Ethernet switch
  - UPS
  - Video recorder (NVR)
  - Video analytics server
- **Peripheral equipment**
  - Switches
  - Access points
  - Directional antennas
  - Communication cabinets

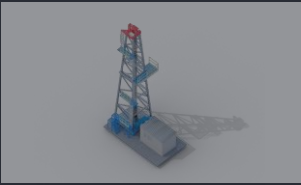
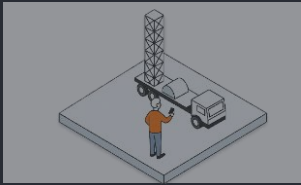
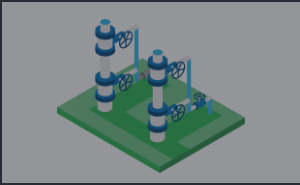
# NVI Solutions pre-designed products for oil & gas

Productified CV technology bundles for oil & gas market

Application	DRILLING	WORKOVER	WELLPADS	TRANSPORT	SURFACE	OFFSHORE	R&D
							
Status and product	Product scaling	Product scaling	Product scaling	Product scaling	Ready for product scaling	Ready for product scaling	<ul style="list-style-type: none"> <li>• Industrial high-risk operations</li> <li>• Construction areas</li> <li>• Underwater operations</li> <li>• Warehouses</li> <li>• Mining areas</li> <li>• Non-production time calculation</li> <li>• Autonomous operations</li> <li>• Drone operations</li> </ul>
	<b>owl.Drill</b> video analytics in drilling	<b>owl.Workover</b> video analytics in well workover and intervention	<b>owl.Wellpad</b> video analytics on wellpads	In-cabin video analytics for transport	Video analytics for surface facilities	Video analytics for offshore facilities	
Installations	150 drilling rigs	270 workover crews	80 wellpads	5 000 vehicles	3 surface facilities	3 offshore platforms	

# NVI Solutions pre-designed products for oil & gas

Video analytics for offshore facilities. Concept



Equipment for control  
from 10 cameras

Control of work zones:

**Entrances to modular facilities, main spans, work zones**



Automatic detection  
14 complete scenarios

As a result of real-time video stream analysis  
**the following are detected:**

- Detection of people appearing on the site, identification of the work zone according to a pre-defined list of zones
- Recognition of PPE presence
- Detection of fire and smoke
- Man down detection
- Restricted areas
- Oil spill detection

And other unsafe acts / unsafe conditions



Personnel informing via  
**Loudspeaker**

Upon system trigger:

**Instant violation notification via loudspeaker and in the system**

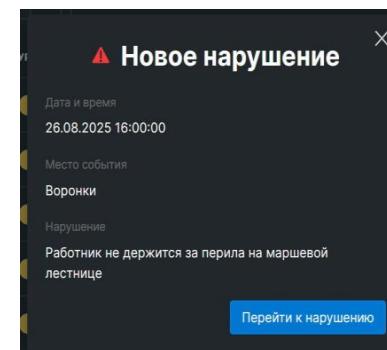

**The system** automatically generates and sends a violation report to the responsible persons

**28 detector for:**

- Presence and actions of personnel;
- Danger zones;
- Location and operation of equipment

**Risk minimization**



- Depressurization of process equipment
- Falls of personnel while working at height





**Report generation**

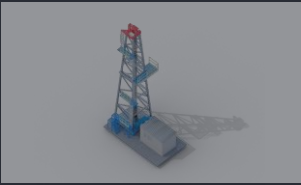
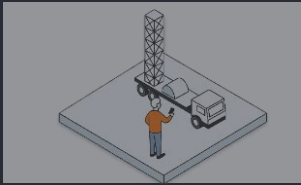
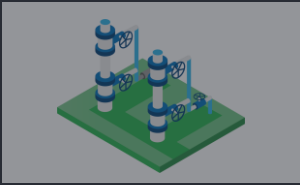

The system automatically generates and sends a violation report to the responsible persons

# NVI Solutions pre-designed products for oil & gas

Productified CV technology bundles for oil & gas market

Application	DRILLING	WORKOVER	WELLPADS	TRANSPORT	SURFACE	OFFSHORE	R&D
							
	Product scaling	Product scaling	Product scaling	Product scaling	Ready for product scaling	Ready for product scaling	
Status and product	<b>owl.Drill</b> video analytics in drilling	<b>owl.Workover</b> video analytics in well workover and intervention	<b>owl.Wellpad</b> video analytics on wellpads	In-cabin video analytics for transport	Video analytics for surface facilities	Video analytics for offshore facilities	<ul style="list-style-type: none"> <li>• Industrial high-risk operations</li> <li>• Construction areas</li> <li>• Underwater operations</li> <li>• Warehouses</li> <li>• Mining areas</li> <li>• Non-production time calculation</li> <li>• Autonomous operations</li> <li>• Drone operations</li> </ul>
Installations	150 drilling rigs	270 workover crews	80 wellpads	5 000 vehicles	3 surface facilities	3 offshore platforms	

# NVI Solutions pre-designed products for oil & gas

Safety and efficiency of underwater operations

## Goals and objectives of underwater video monitoring:

1. Monitoring the completeness of work execution, both in the case of human presence and during ROV operations
2. Monitoring personnel safety during dives by a person on the surface
3. By capturing anomalies and transmitting video streams in real time, rapid detection and response to anomalies are possible
4. Video streams serve as evidence that the work was carried out according to the complete checklist
5. Complementing the precision of ROV operations
6. When using expensive ROVs, it is possible to monitor the safety and efficiency of their operation

## Supporting technologies:

1. Underwater wearable DVRs
2. ROVs with the capability to record photo and video materials on board, along with sensor data on the nature of their movement
3. Solutions for transmitting video images to the surface via fiber-optic cables (up to 150-200 m)



# NVI Solutions pre-designed products for oil & gas

Safety and efficiency of underwater operations

## Specifics of creating and collecting data for training neural networks for underwater operations:

- Public underwater defect datasets are practically non-existent – each project is unique
- Articles on the application of video analytics with a recognition accuracy of 88–94% are based on private tests with data volumes ranging from 150 to 3,000 frames, and third-party results cannot be reproduced
- There is no single benchmark — each tech company tests on its own data and is responsible for the quality of its collection

## Key competencies of NVI Solutions for underwater projects:

- **Synthetic data generation** — we create training datasets when real data is scarce, which is critical for a cold start
- **Underwater image processing** — we developed software for underwater smartphone photography: color correction, turbidity removal, contrast restoration
- **Detection of objects and events** at oil and gas industrial facilities – we have extensive experience in solving tasks of identical complexity
- **Full-cycle services** — labeling, training, implementation, recognition quality monitoring

Инструментарий лаборатории  
синтетических данных

# NVI Solutions pre-designed products for oil & gas

Safety and efficiency of underwater operations



[ 5 ]



**Customer success story:  
major oil & gas corporation in EMEA**

Incident rate decrease by 94% in 13 months

# Customer success story: major oil & gas corporation in EMEA

## Customer challenge and solution overview

### Challenge

In high-risk drilling environment operators struggled with a reactive safety culture and a lack of continuous monitoring. Key challenges included severe risks to personnel from undetected hazards, costly operational downtime caused by avoidable incidents, and technological process disruptions.

### Solution

NVI Solutions deployed a fully autonomous, on-premise solution that operates 24/7/365 in a secure, closed-loop environment without external network access.

At its core, the system runs **24 complex, AI-driven video analytics scenarios** distributed across **17 cameras** installed in critical zones, proactively automating safety, efficiency, and quality control.

#### General personnel industrial safety

- Missing PPE (hard hats, safety glasses, face shields, or respirators) among personnel
- Exposed skin or lack of protective outerwear when handling chemicals
- Workers using stairways without holding handrails

#### Red zone management and proximity hazards

- Unauthorized presence in special zones during critical operations
- Personnel on rig floor while power tongs are engaged
- Personnel on rotary table during top drive movement

#### Personnel safety while working at heights

- Stepping outside the monkey board guardrails
- Failure to use anchored safety harness (>1.8m above floor)
- Unanchored safety harness while working on the monkey board

#### Confined spaces and access Control

- Confined space entry without a standby person
- Entering tank hatches without SCBA and safety harness
- Unattended open hatches on tanks or wells

#### Drilling operations and well control

- Premature dismantling of BOP before cement sets
- Racking pipes before the traveling block completely stops
- Drilling fluid overflow without active circulation

#### Equipment maintenance and inspections

- Maintenance on auger conveyor with covers open and motor running
- Failure to perform visual inspections of the drilling line

# Customer success story: major oil & gas corporation in EMEA

Investigation process that was established from customer

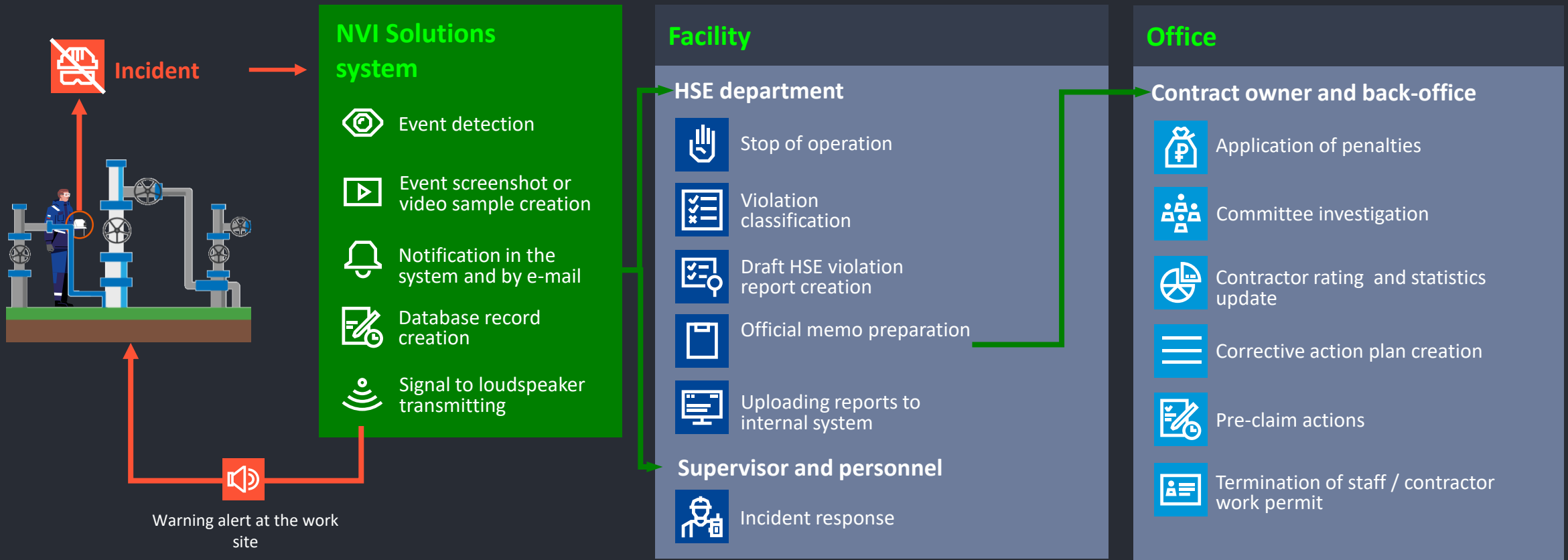

Explanatory note
 Instructions / testing
 Warning / reproach
 Suspension from work / termination of work permit

# Customer success story: major oil & gas corporation in EMEA

Incident rate decrease by 94% in 13 months after deployment

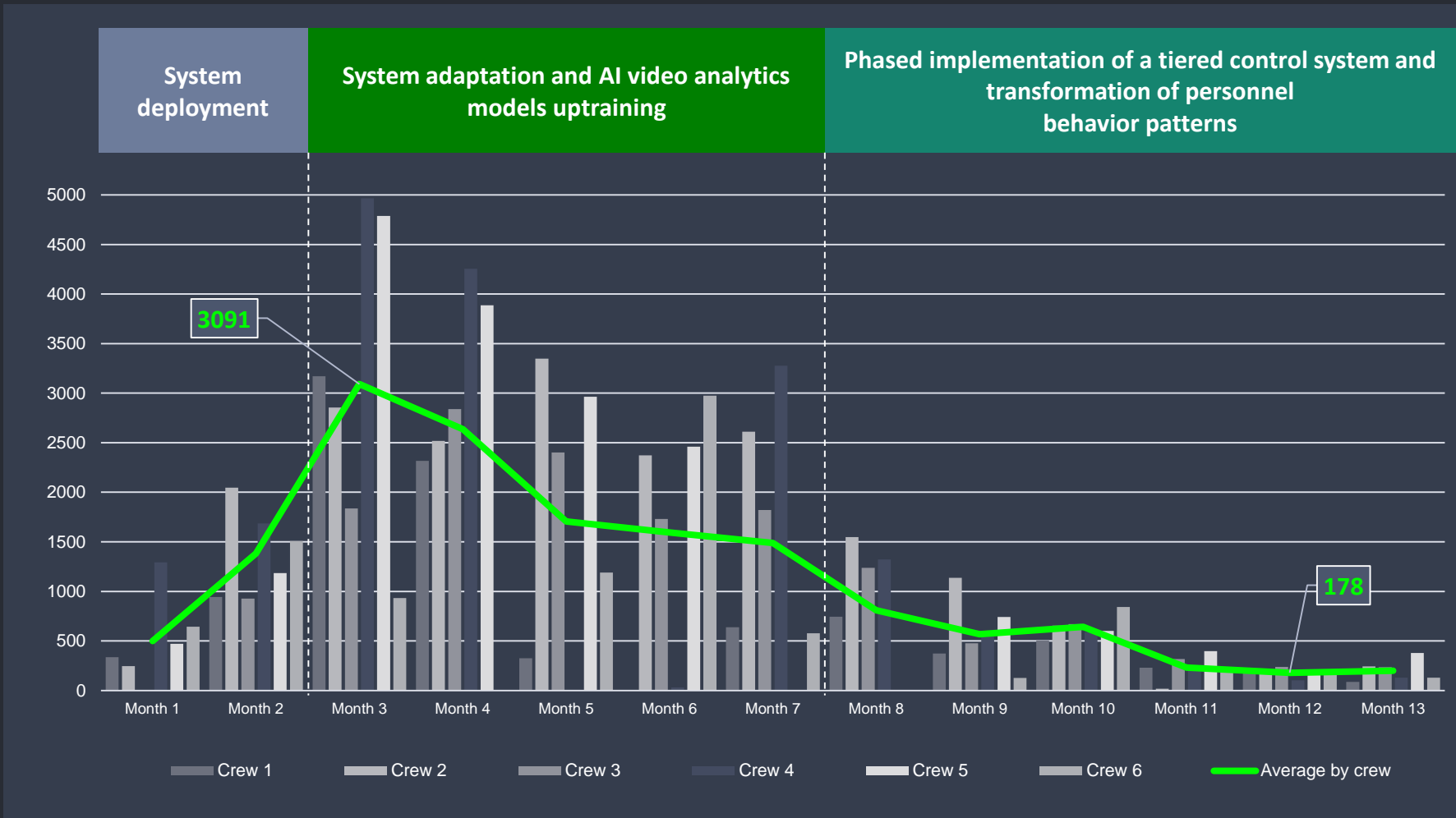

Overall average number of hazardous detections per drilling crew

**Decreased by 94%**

This overall reduction was consistent across all severity levels:

**Severe** – by 92%

**Significant** – by 97%

**Minor** – by 90%

[ 6 ]



## NVI Solutions high-level project roadmap proposal

Main stages and proposed durations



# NVI Solutions high-level project roadmap proposal

Deployment basic roadmap proposal to discuss

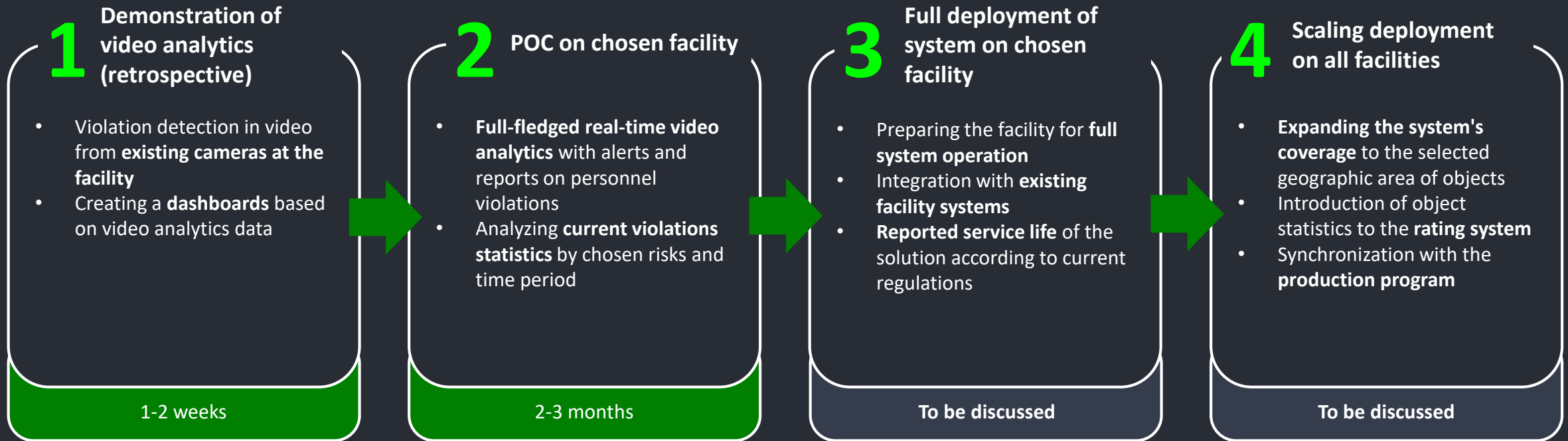

Quick demonstration of work on the **existing infrastructure of the facility**



Adapted design solutions for **real-world tasks** and facility designs



The system operates in a **local data loop at sites** without using an external network



info@nvi-solutions.com  
www.nvi-solutions.ru  
www.nvi-solutions.com

